

Instruction Manual for LAC series ovens

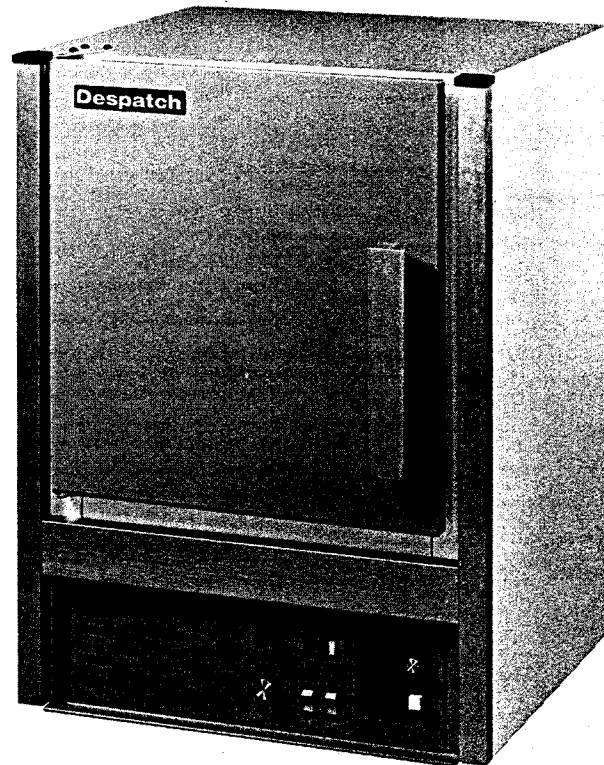

LAC series Despatch ovens are bench ovens to 260°C (500°F) with forced convection airflow.

MODEL	VOLTS	HEATER WATTS	AMPS	HZ	PHASE
LAC1-10	120	1000	10.0	50/60	1
LAC1-38A	120	1600	16.0	50/60	1
LAC1-38B	240	1800	9.4	50/60	1
LAC1-67	240	2400	11.6	50/60	1
LAC2-12	240	3600	18.3	50/60	1

TABLE OF CONTENTS

Warnings.....	3
Introduction	3
Unpacking & Inspection.....	3
Installation.....	4
Power Connection.....	4
Control Terminology.....	4
Pre-Start Up.....	5
Start-Up.....	5
Operation.....	6
Check Safety Controls	6
Ventilation.....	6
Practice Safety	6
Initial Start-Up	6
Starting The Oven	6
Loading The Oven	7
Shutting Down The Oven	7
Service And Maintenance.....	7
Replacing	
— Hi-Limit.....	7
— Heater Unit	7
— Fan Motor.....	8
— Control	8
Recalibrating Control or Hi-Limit.....	8
Troubleshooting.....	9
Electric Schematics	10-15
Warranty	16

Warnings

FAILURE TO HEED WARNINGS IN THIS INSTRUCTION MANUAL AND ON THE OVEN COULD RESULT IN DEATH, PERSONAL INJURY OR PROPERTY DAMAGE.

DANGEROUS ATMOSPHERE

Do not use oven in wet, corrosive or explosive atmospheres unless this oven is specifically designed for a special atmosphere.

FLAMMABLES

Do not use any flammable solvent or other flammable material in this oven.

Do not process closed containers of any substance or liquid in this oven because they may explode under heat.

OPERATOR TRAINING REQUIREMENTS

The users and operators of this oven must comply with operating procedures and training of operating personnel as required by the Occupational Safety and Health Act (OSHA) of 1970, Section 5 and relevant safety standards, as well as other safety rules and regulations of state and local governments. Refer to the relevant safety standards in OSHA and National Fire Protection Association (NFPA), Section 86A or 1977, Chapter 1, Section 1-6 and Appendix F or any subsequent editions.

SERVICING OVEN

Do not attempt any service on this oven before opening main power disconnect switch.

OVEN TEMPERATURE LIMIT

Do not attempt to exceed the maximum operating temperature of this oven.

PRODUCT TEMPERATURE LIMIT

If the product on which the oven is being used has a critical high temperature limit, the high-limit control should be used as a "Process" high-limit rather than as an "Oven" high-limit control. When used as a "Process" high-limit, the high-limit control should be set to a temperature somewhat below the temperature at which the product would be damaged. The oven controller or a pyrometer could be used to determine the "Process" high-limit setting. If the destructive temperature of the product is already known, this could be used as a point below which the "Process" high-limit could be set.

NOTICE: Despatch Industries, Inc. cannot be responsible for either the process or process temperature used, or for the quality of the product being processed. It is the responsibility of the purchaser and operator to see that the product undergoing processing in a Despatch oven is adequately protected from damage. Carefully following the instructions in this manual will assist the purchaser and operator in fulfilling that responsibility.

WARNING SIGNS MISSING

If it appears that any warning, danger, caution or information label or sign has been damaged or lost, contact Despatch Industries, Inc. for replacements. Call or write:

Customer Service
Despatch Industries, Inc.
P.O. Box 1320
Minneapolis, MN 55440
Call Toll Free 800-328-5476
(in Minnesota 800-462-5396)

Introduction

The users of this oven must comply with operating procedures and training of operating personnel as required by the Occupational Safety and Health Act (OSHA) of 1970, Section 5 and relevant safety standards, as well as other safety rules and regulations of state and local government. Refer to the relevant safety standards in OSHA and National Fire Protection Association (NFPA), Section 86A of 1977, Chapter 1, Section 1-6 and Appendix F, or any subsequent editions.

NOTE: Read the entire introduction to this manual before installing the oven.

This instruction manual covers installation, operation, and maintenance of the "LAC" series ovens.

An efficient way to learn about the oven would be to read the manual while working with the corresponding oven control system. This will give a practical hands-on relationship between the information in the manual and the physical oven.

While reading this manual, if a term or section of information isn't fully understood, look up that item in the appropriate section to familiarize yourself with that item. Then go back and reread that section again. Information skipped, not understood or misunderstood could create the possibility of operating the equipment in an unsafe manner, cause damage to the oven or personnel, or reduce the efficiency of the equipment.

— If anything is found to be out of order, check the rest of the oven very carefully for some other damage that could have occurred at the same time.

IF THERE IS DAMAGE, AND IT COULD HAVE HAPPENED DURING SHIPMENT, CONTACT THE SHIPPER IMMEDIATELY, AND FILE A FORMAL, WRITTEN DAMAGE CLAIM.

After you have filed a written damage claim with the shipper, contact Despatch Industries, Inc. to report your findings and to order replacement parts for those that were damaged or missing. Please send a copy of your filed damage claims to Despatch.

To return parts contact Despatch Industries to obtain an MRA (material return authorization) number. This number must be attached to the returned part for our identification. If required, a new part will be sent and invoiced to you. When the return part is received, credit will be given, if in warranty.

Unpacking & Inspection

This shipment should include:

- One Despatch Oven
- One Instruction Manual
- Warranty Card
- Two shelves
- One package containing four rubber feet.

Unpacking & Inspection

Remove all packing materials and thoroughly inspect the oven for damage of any kind that could have occurred during shipment.

- See whether the carton and plastic cover sheet inside carton are still in good condition.
- Look at all outside surfaces and corners of the oven for scratches and dents.
- Check the oven controls and indicators for normal movement, bent shafts, cracks, chips and missing parts such as knobs and lenses.
- Check the door and latch for smooth operation.

Installation

Remove the adhesive backing sheet from the rubber feet and attach the rubber feet to the bottom corners of the oven.

Place the oven on a bench top or an optional cabinet base. The oven must have a minimum of 2" clearance in the rear to provide proper ventilation but may be placed next to another cabinet or oven with ¾" clearance (the doors will still open.)

Make sure oven is level and plumb; this will assure proper heat distribution and operation of all mechanical components.

Power Connection

Be sure the oven is connected to the power source indicated on the specification plate. Plug the oven directly to your electric supply, with all grounding and safety equipment in compliance with applicable codes, ordinances and accepted safe practices.

Line voltages may vary in some geographical locations. If your line voltage is much lower than the oven voltage rating, warm-up time will be longer and motors may overload or run hot. If your line voltage is higher than name plate rating the motor may run hot and draw excessive amps.

If the line voltage varies more than $\pm 10\%$ from the oven voltage

rating, some of the electrical components such as relays, temperature controls, etc. may operate erratically.

The LAC1-10 oven uses a standard 120 volt, 15 amp circuit.

The LAC1-38A uses a standard 120 volt, 20 amp circuit.

The LAC1-38B and LAC 1-67 use a standard 240 volt, 15 amp circuit.

The LAC2-12 must be hardwired to the electric supply using 10 AWG or larger wires suitable for at least 75°C (167°F).

Ovens designed for 240 volts (see name plate on oven) will operate satisfactorily on a minimum of 208 volts, but with a reduction in heater power. If your power characteristics are lower, contact Despatch Industries, Inc.

Control Terminology

ON-OFF CONTROLLERS

Turn the heater off when the setpoint is reached. The temperature continues to rise somewhat due to the inertia of the system, and then begins dropping. When the temperature falls below the setpoint the heater will turn on again. This produces a temperature swing between turn-on and turn-off of several degrees.

HIGH-LIMIT

If the product on which the oven is being used has a critical high temperature limit, the high-limit control should be used as a "Process" high-limit rather than as an "Oven" high-limit control.

When used as a "Process" high-limit, the high-limit control should be set to a temperature somewhat below the temperature at which the product would be damaged. The oven control or a pyrometer could be used to determine the "Process" high-limit setting. If the destructive temperature of the product is already known, this could be used as a point below which the "process" high-limit could be set.

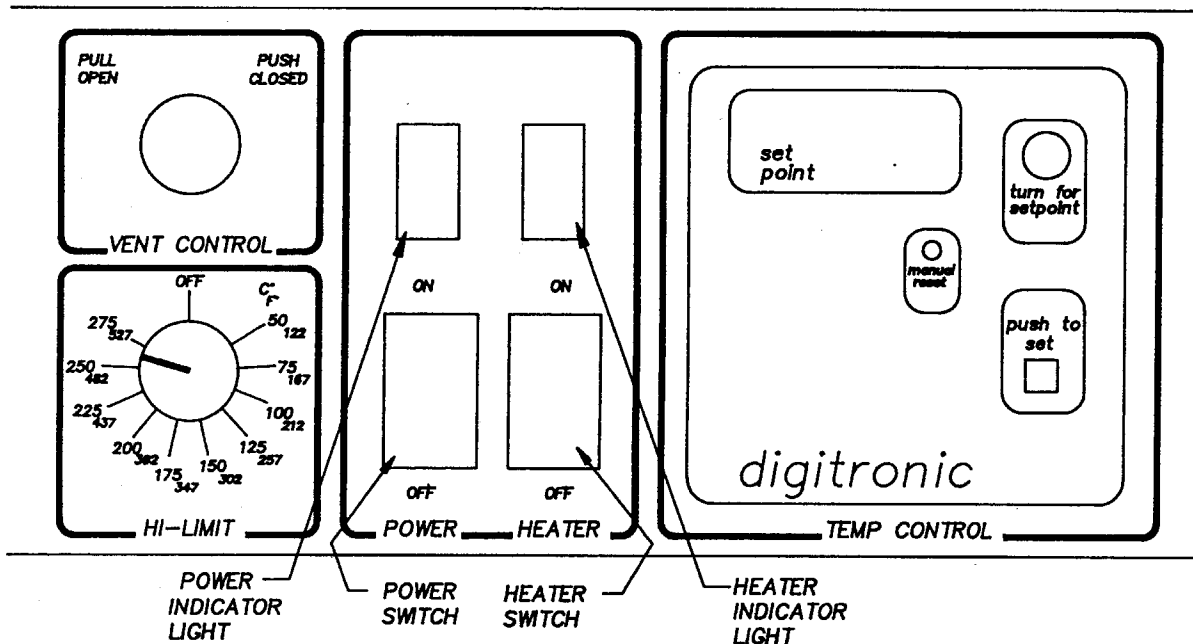

Warnings

FAILURE TO HEED WARNINGS IN THIS INSTRUCTION MANUAL AND ON THE OVEN COULD RESULT IN DEATH, PERSONAL INJURY OR PROPERTY DAMAGE.

DANGEROUS ATMOSPHERE

Do not use oven in wet, corrosive or explosive atmospheres unless this oven is specifically designed for a special atmosphere.

FLAMMABLES

Do not use any flammable solvent or other flammable material in this oven.

Do not process closed containers of any substance or liquid in this oven because they may explode under heat.

OPERATOR TRAINING REQUIREMENTS

The users and operators of this oven must comply with operating procedures and training of operating personnel as required by the Occupational Safety and Health Act (OSHA) of 1970, Section 5 and relevant safety standards, as well as other safety rules and regulations of state and local governments. Refer to the relevant safety standards in OSHA and National Fire Protection Association (NFPA), Section 86A or 1977, Chapter 1, Section 1-6 and Appendix F or any subsequent editions.

SERVICING OVEN

Do not attempt any service on this oven before opening main power disconnect switch.

OVEN TEMPERATURE LIMIT

Do not attempt to exceed the maximum operating temperature of this oven.

PRODUCT TEMPERATURE LIMIT

If the product on which the oven is being used has a critical high temperature limit, the high-limit control should be used as a "Process" high-limit rather than as an "Oven" high-limit control. When used as a "Process" high-limit, the high-limit control should be set to a temperature somewhat below the temperature at which the product would be damaged. The oven controller or a pyrometer could be used to determine the "Process" high-limit setting. If the destructive temperature of the product is already known, this could be used as a point below which the "Process" high-limit could be set.

NOTICE: Despatch Industries, Inc. cannot be responsible for either the process or process temperature used, or for the quality of the product being processed. It is the responsibility of the purchaser and operator to see that the product undergoing processing in a Despatch oven is adequately protected from damage. Carefully following the instructions in this manual will assist the purchaser and operator in fulfilling that responsibility.

WARNING SIGNS MISSING

If it appears that any warning, danger, caution or information label or sign has been damaged or lost, contact Despatch Industries, Inc. for replacements. Call or write:

Customer Service
Despatch Industries, Inc.
P.O. Box 1320
Minneapolis, MN 55440
Call Toll Free 800-328-5476
(in Minnesota 800-462-5396)

A. PRE-START UP

1. KNOW THE SYSTEM

Read this manual carefully. Make use of its instructions and explanations. The "Know How" of safe, continuous, satisfactory, trouble free operation depends primarily on the degree of your understanding of the system and of your willingness to keep all parts in proper operating condition.

2. CHECK LINE VOLTAGE

This must correspond to nameplate requirements of motors and controls. A wrong voltage can result in serious damage. See "Power Connection."

3. FRESH AIR AND EXHAUST

Do not be careless about restrictions in and around the fresh air and exhaust openings and stacks. Under no condition, permit them to become so filled with dirt that they appreciably reduce the air quantity. See "Installation."

B. START-UP

1. START FAN

With door open, turn on power. You will hear fan start. Air is discharged from the left side wall.

2. ADJUST HI-LIMIT TO OPERATING POSITIONS

The hi-limit thermostat can be used for the protection of the equipment or the product against excessive temperatures when set properly.

Hi-limit thermostats of the non-indicating type (ones which do not show the temperature) can be properly set only after oven is in operation. Until then, such thermostats should be set at their maximum positions so all preliminary testing and adjusting can be done. Before putting oven into production, adjust this type of thermostat as follows: Set the temperature control thermostat at 14°C (25°F) above the desired operating temperature. Operate oven until the control thermostat is regulating. Carefully adjust the hi-limit downward until it trips. Reset the temperature control thermostat at the desired operating temperature. The two instruments are now set in their correct positions.

NOTE: It will be necessary to reset the hi-limit instrument whenever it has tripped. The hi-limit may be reset by first allowing the oven chamber to cool slightly (or turning the hi-limit thermostat up several degrees) and pushing the red reset button.

NOTE: Never operate oven at a temperature in excess of the maximum operating temperature which is 260°C (500°F).

NOTE: All ovens are tested at the factory; however, shipping may cause damage or deviation. Therefore, before oven is put into regular service, the following items should be inspected and adjusted if necessary: thermostat calibration, doors, hinges, latches and other miscellaneous parts.

3. OPTIONAL PROCESS TIMER (SPRING WOUND)

Turn process timer to the desired time interval. The heater will shut off after the timer times out. Turn the timer knob to the hold position to eliminate the timer function.

C. OPERATION

1. KEEP EQUIPMENT CLEAN

Gradual dirt accumulation retards air flow. A dirty oven can result in unsatisfactory operation such as unbalanced temperatures in the work chamber, reduced heating capacity, reduced production, overheated components, etc.

Keep the walls, floor and ceiling of the oven work chamber free of dirt and dust. Floating dust or accumulated dirt may produce unsatisfactory results.

Keep all equipment accessible. Do not permit other materials to be stored or piled against it.

2. PROTECT CONTROLS AGAINST EXCESSIVE HEAT

This is particularly true of controls, motors or other equipment containing electronic components. Ambient temperatures in excess of 51.5°C (125°F) should be avoided.

3. ESTABLISH MAINTENANCE AND CHECK-UP SCHEDULES

Do this promptly and follow them faithfully. Careful operation and maintenance will be more than paid for in continuous, safe and economical operation.

4. MAINTAIN EQUIPMENT IN GOOD REPAIR

Make repairs immediately. Delays may be costly in added expense for labor and materials and in prolonged shut down.

5. LUBRICATION

Fan motor bearings are permanently lubricated.

All door latches, hinges, door operating mechanisms, bearing or wear surfaces should be lubricated to ensure easy operation.

D. CHECK SAFETY CONTROLS

This should be done as indicated.

Make these tests carefully and do them regularly. The safety of personnel as well as the equipment may depend upon the proper operation of any one of these controls at any time.

1. TEMPERATURE CONTROL (40 hours)

Observe heater indicator light to insure that the heater is cycling off.

2. HI-LIMIT (40 hours)

With the oven operating at a given temperature, gradually turn the hi-limit control knob down to the set point operating temperature. The hi-limit is in control when the heater indicator light shuts off. Push the hi-limit reset button to reset the hi-limit after returning the thermostat to its original setting.

E. VENTILATION

There is an exhaust opening in the rear of the unit that is always open. The fresh air can be adjusted open or closed by adjusting the push/pull vent mechanism on the control panel.

F. PRACTICE SAFETY

Make it a prime policy to "know what you are doing before you do it." Make CAREFULNESS, PATIENCE and GOOD JUDGEMENT the safety watchwords for the operation of your oven.

Initial Start-Up

1. LEVEL OVEN

The oven needs to be level to ensure proper heat distribution and operation of mechanical parts.

2. ROOM ATMOSPHERE

The oven room atmosphere should be kept free of dirt and dust. Good results depend on a clean work space.

Starting the Oven

1. Push power switch to "ON" (indicator light should light). This activates the fans and control circuit.
2. Press and hold "push-to-set" button on the Digitronic™ temperature control. The display will be in the set point mode and the set point indicator light is on as long as the button is depressed.
3. Rotate "turn-to-set" knob until the desired chamber temperature is displayed. Release the "push-to-set" button. Note that the set point will be changed if knob is turned when button is not depressed.
4. Set hi-limit device by rotating hi-limit control knob to 10-15°C (18-27°F) above process temperature. Set point should be low enough to prevent damage to the workload but high enough to allow the Digitronic to control at set point. Hi-limit will shut off heater if chamber temperature exceeds high limit set point.
5. Push heater switch to "ON". Heater indicator light should light. This activates the heating elements. When the desired temperature is reached, the Digitronic will proportion power to the heater as needed and the heater indicator light will flash on and off.
6. The readout area will alternately display set point and actual chamber temperature. Set point is on display when the small light shows above the "set point" label.
7. Oven set point can be displayed at any time by manually depressing and holding the "push-to-set" button. This will not disengage the control function.

For fastest oven heat-up time, close the vent, which is adjustable for varying degrees of ventilation. After desired temperature is reached, vent may be adjusted as needed. Examples: 1) for drying operations, open vent to prevent buildup of moisture within the oven; 2) for sample heating, close the vent when no ventilation is required.

Loading the Oven

1. Avoid spills of anything onto the heater elements or floor of oven.
2. The two shelves are designed to be pulled out about half-way without tipping.
3. The support capacity of the shelves is 25 pounds. Do not overload the shelves.
4. Do not place the load on the oven floor plate. Placing the load on the oven floor plate may cause the load to heat unevenly and the weight may cause shorting out of the heater elements. Use the shelves provided.
5. Distribute workload evenly so that airflow is not restricted.
6. Do not overfill your oven. The workload should not take up more than two-thirds of any dimension of the inside cavity.

Shutting Down the Oven

1. Push the heater switch to "OFF" after the heating cycle is complete.
2. Do not turn the power off until the oven temperature is below 150°C (302°F). If the oven is turned off before it is properly cooled, the fan shaft and motor bearings may become overheated, shortening the life of the motor.

Warning

Hot surfaces may exist around door, inside cabinet, product, and fixtures. Handle with care.

Service and Maintenance

Warnings

FAILURE TO HEED WARNINGS IN THIS INSTRUCTION MANUAL AND ON THE OVEN COULD RESULT IN DEATH, PERSONAL INJURY OR PROPERTY DAMAGE.

SERVICING OVEN

Do not attempt any service on this oven before opening main power disconnect switch.

Warning

High voltage is present on terminals inside control cabinet. Voltage checks and adjustments are to be made only by a qualified electrical maintenance person such as electrician or technician. Failure to heed this warning could result in death, serious bodily injury or property damage.

CLEAN-UP AFTER SERVICING

After any service or repair work has been done on the oven, thoroughly clean the chamber, inside the control cabinet and around the oven.

The stainless steel interior may be routinely cleaned with a mild cleaning agent such as ammonia, or detergent and water. The

cleaning agent should be applied with a damp sponge or cloth.

Stubborn deposits may be cleaned by using a household oven cleaner.

Powder type cleansers should be used cautiously since many of these products contain ingredients which may scratch the interior of the oven.

REPLACING PARTS

NOTE: When ordering parts or service, give oven model and serial number or part number if known.

DOOR HINGES AND LATCHES

Check operation of the chamber door to see whether it opens easily and closes securely, without jerking or slamming.

CONTROLS AND INDICATORS

Check all controls and indicators for proper operation: switches should move easily, indicators should light or give correct signal, and controls should perform intended function. See descriptions in "Controls and Indicators" and "Initial Start-Up" for details.

WARNING — Disconnect main power switch or power cord before attempting any repairs or adjustments.

Replacing the hi-limit (Tools needed: screwdriver, ¼" socket set)

- Disconnect power. Remove the screws from the face of the control panel and slide it forward.
- Locate control thermocouple and hi-limit bolt along the left side of the control chamber.
- Loosen the nut on the brass fitting holding the hi-limit capillary in place.
- Pull hi-limit capillary out of the fitting. NOTE: Avoid rough handling.
- Carefully uncoil the new capillary tube, taking care not to kink it.
- Feed the new hi-limit capillary through the nut and ferrule and place back into the fitting.
- Retighten the fitting nut.
- Detach the old hi-limit body by unscrewing the mounting screws retaining the hi-limit.
- Remove the hi-limit and discard.
- Attach the new hi-limit. Reattach the knob.
- Replace control panel.

NOTE: The hi-limit has been calibrated at the factory but recalibration may be necessary. Refer to the section in this manual on recalibration.

Replacing heater unit (Tools needed: crescent wrench, screwdriver, ¼" socket set)

- Remove floor plate by removing screws and lifting it out.
- Disconnect heater leads from heater element with wrench. Note which wires go on which terminals.
- Unscrew the screws holding the frame to the oven body. Remove the heater and discard.
- Screw down new heater frame.
- Attach heater leads to appropriate terminals.
- Replace interior floor and screws.

Replacing the fan motor (Tools needed: screwdriver, 5/32" Allen wrench, 1/4" socket set)

- Remove floor plate by removing screws and lifting it out.
- Loosen two set screws on fan wheel in middle of oven bottom by going through the heater or by disconnecting the heater and removing it to gain access.
- Turn oven on its back and remove bottom plate.
- Unscrew the four screws holding motor mounts to body.
- Remove motor. (Note: After fan wheel runs at temperature for awhile, it will stick to the shaft. Some force may be required to separate the two.)
- Disconnect motor leads from terminal strip on control panel.
- Take motor mounts off motor.
- Put motor mounts onto new motor.
- Reattach fan wheel to shaft by inserting shaft into shaft collar. (Put wheel onto shaft from inside of oven.)
- Reattach motor mounts to oven body making sure grommets are in place.
- Attach motor lead wires to terminal strip (See wiring diagram.)
- Replace oven bottom and turn oven right side up.
- Adjust fan wheel for 3/16" clearance between wheel and inlet ring.
- Tighten set screws. (Make sure set screws hit the flats machined onto the motor shaft.)
- If heater was removed, replace it.
- Replace interior floor and screws.

Replacing the control (Tools needed: screwdriver, 1/4" socket set)

- Disconnect power. Remove screws from the face of the control panel and slide it forward.
- Locate the Digitronic printed circuit (PC) board.
- Remove wires from terminal strip, noting which numbered wires connect to which terminals. Refer to wiring diagram in this manual.
- Remove the screws holding the terminal board onto sub-panel. Replace old PC board with new PC board. Attach board to sub-panel.
- Reattach wires to terminal strip making sure the correct ones are connected.
- Replace control panel.

Recalibrating the hi-limit (Tools needed: small screwdriver)

NOTE: If oven temperature and hi-limit dial setting disagree by more than 25°, the hi-limit needs recalibration.

- Turn oven on and set controller at 175°C. It should be stabilized at temperature for about 1 hour before adjustments are made.
- Pull hi-limit knob off. Calibration screw is located in center of thermostat shaft. (See photo below.)
- 1/4 turn of the screw equals approximately 20°C. (See diagram.)

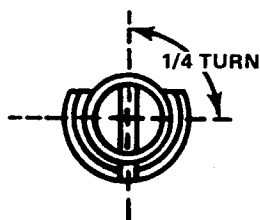
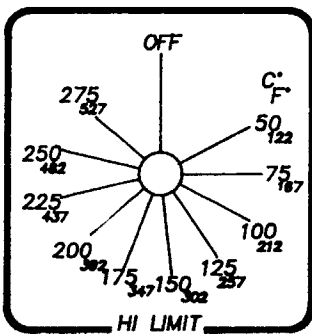

- If hi-limit set point is higher than actual oven temperature, turn calibration screw counterclockwise. If set point is lower than actual temperature, turn screw clockwise.
- Replace knob on shaft.
- If readings do not coincide within 30 minutes, repeat operation.

Digitronic Control

Manual Reset Adjustment

When operating the oven at different temperatures and damper settings, the setpoint may vary from the oven temperature. Align these two readings as follows:

1. Turn oven ON and allow the oven to cycle off and on at the desired setpoint for 15 minutes.
2. If the oven temperature is below the setpoint on the display, turn the "manual reset" adjusting screw clockwise. If the oven temperature is above the setpoint on the display, turn the "manual reset" adjusting screw counterclockwise. 1/16 turn of the pot is equal to approximately 1°C (2°F). Adjust the "manual reset" screw until the setpoint and display read the same. The "manual reset" adjusting screw is located on the faceplate of the control instrument.

Thermocouple break protection

If the thermocouple breaks, the Digitronic will shut off power to the heater, preventing excessive temperature in the chamber. This condition will be indicated on the Digitronic digital display area by decimal points between the numerals.

The Controller thermocouple is type "J" (iron/constantan) and is replaceable using the following procedure:

1. Disconnect power and remove screws from the face of the control panel and slide it forward.
2. Locate thermocouple and hi-limit bulb along the left side of the control chamber.
3. Loosen the nut on the fitting holding the thermocouple in place.
4. Pull thermocouple out of brass fitting.
5. Feed new thermocouple through the nut and ferrule and place back into the fitting.
6. Retighten the fitting nut.
7. Remove old thermocouple from terminals marked "TC+" and "TC-" on PC board.
8. Attach new thermocouple to "TC+" and "TC-" making sure that white lead is attached to the "+" terminal and the red lead is attached to the "-".
9. Replace oven control panel.
10. If decimal points still appear between numerals, repeat procedure.

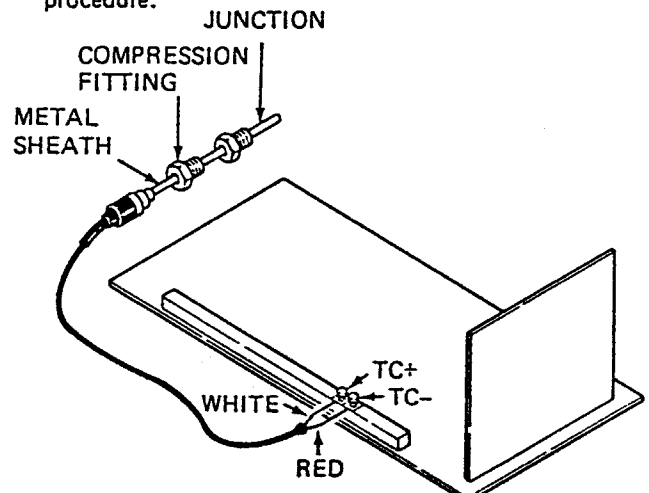

Digitronic trouble-shooting DIFFICULTY

DIFFICULTY	PROBABLE CAUSE	SUGGESTED REMEDY
Erratic Sensor Readout	Broken T/C Control Malfunction	See Thermocouple Test See Control Output Test
Erratic Setpoint Readout	Bad Slide Wire on 5K Potentiometer Control Malfunction	See Potentiometer Test See Potentiometer Test
Inaccurate Temperatures	Control Miscalibration	See Calibration Test
Decimal Points Between the Numerals Sensor Readout	Thermocouple is Open or Broken	See Thermocouple Break Protection
Setpoint Readout	Overrange	Lower Setpoint Potentiometer or Input Signal Voltage

Tests

WARNING – HIGH VOLTAGE IS PRESENT ON TERMINALS. VOLTAGE CHECKS TO BE MADE ONLY BY QUALIFIED ELECTRICAL MAINTENANCE PERSONNEL: E.G., ELECTRICIAN OR TECHNICIAN. FAILURE TO HEED THIS WARNING CAN RESULT IN SERIOUS BODILY INJURY, PROPERTY DAMAGE, OR DEATH.

Thermocouple Test:

1. Place a jumper or short the terminals "TC+" and "TC-" on the control. The display should read ambient temperature and be very stable.
2. Replace the control if the unit is not stable.

Control Output Test:

1. Disconnect line power from the control.
2. Remove the jumper or leads attached to terminals + and - on the control.
3. Attach a multimeter with internal impedance greater than 10,000 OHMS/volt DC across these terminals.
4. Set meter to 30 VDC range.
5. Reconnect line power to the control.
6. The meter should read approximately 10 VDC when the sensor readout is 10°C below setpoint and 0 VDC when the readout is 10°C above setpoint. The voltage should be fluctuating when both the sensor and setpoint readouts are the same.
7. Replace control if the unit does not respond as above.

Potentiometer Test:

Control:

1. Remove potentiometer leads P₁, P₂, and P₃ from their corresponding terminals. Short terminals P₂ and P₁ together. The resulting display should be steady and indicate 000.
2. Replace control if the readout is not stable.

Setpoint Potentiometer

1. Turn the pot all the way clockwise and then all the way counterclockwise several times. This should remove any dust or dirt from the slidewire. The setpoint should stable. Replace pot if the readout is still not stable.

Range Adjustment:

1. Turn setpoint adjustment pot fully clockwise, this will cause the display to indicate the maximum temperature. Locate the "SP RANGE" potentiometer on the digitronic board. Turn this potentiometer adjusting screw clockwise to increase the maximum setpoint temperature.

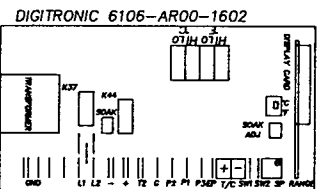

Calibration procedure

1. Disconnect line power to the control.
2. Attach an accurate potentiometer with an ambient compensated millivolt of Type "J" thermocouple output to the "TC+" and "TC-" terminals on the control (see Section 12.2).
3. Set Digital Voltmeter (DVM) to 30 VDC range.
4. Turn the line voltage on.
5. Set reset and soak adjust pots to mid range. See Figure 1B & 1C.
6. Set °C/°F switch to °C. Allow unit to warm up 15 minutes before calibration.
7. Connect digital voltmeter (DVM) from COM (-) J69 Plug Pin #4 to W113 (+). Set millivolt source to 0°C (0.00 mv). Adjust °C lo pot for 0.00V +/- .005V on DVM. Adjust zero pot for 000 on display when LED (6) indicator on the front of the control is off.
8. Set millivolt source to 540°C (29.64 mv). Adjust °C hi for 2.700V +/- .005V on DVM. Adjust F.S. pot for 540 on display when LED (6) indicator is off.
9. Repeat steps 7 and 8 as necessary.
10. Set millivolt source to 260°C (14.11 mv), display should read 260 +/- 1 when LED (6) indicator is off.
11. Set °C/°F switch to °F.
12. Set millivolt source to 32°F (0.00 mv). Adjust °F lo pot for 32 on the display when LED (6) indicator is off.
13. Set millivolt source to 990°F (29.20 mv). Adjust °F hi pot for 990 on the display when LED (6) indicator is off.
14. Repeat steps 12 and 13 as necessary.
15. Set millivolt source to 500°F (14.11 mv), display should read 500 +/- 1 when LED (6) indicator is off.
16. Connect DVM from COM (-) J69 Plug Pin #4 to W116(+). Adjust set pot (see figure 1C) for 2.500V on DVM. With set point switch depressed, adjust the balance pot for 500 on display.
17. Adjust the reset pot until the load is cycling 50 percent. The cycle time should be about 1 second +/- ¼ second. LED (41) should cycle with the load.
18. Disconnect all power and leads if necessary.
19. Place nail polish on the zero, °C/°F Hi & Lo, FS adjust, and bal. adjust pots.
20. Place °C/°F selection switch to desired setting.

Troubleshooting

Any equipment operating for as many hours a day as lab ovens often do is likely to have problems now and then. Below are possible problems and suggested solutions. If you have a problem not listed and don't know what to do, contact Despatch at our toll free "Help Line" 800-328-5476 (In MN 800-462-5396).

DIFFICULTY	PROBABLE CAUSE	SUGGESTED REMEDY
Failure to heat	No power	Check power source and/or oven and wall fuses
	Broken or frayed cord	Replace with new cord and plug set
	Burned out heating element	Replace element (see warranty statement, back page)
	Control malfunction	Replace controller
Slow heat up	Loose wire connections	Disconnect power and check connections behind control panel
	Improperly loaded	Reduce load or redistribute load in chamber
	Low line voltage	Supply sufficient power and proper connections. Check to see if circuit is overloaded
	1 or 2 heating elements are burned out	Replace burned out element (see warranty statement, back page)
	240 volt oven is connected to a 208 volt line	Raise line voltage
	Fan motor failure	Replace fan motor
Frequent heater element burn out	Harmful fumes generated by load	Increase vent opening or discontinue process
	Spillage or splattering of material on heating elements	Disconnect power and clean oven chamber and elements
	Overheating oven	Do not operate over 204°C (400°F)
Erratic temperatures	Control malfunction	Replace control unit
Inaccurate temperatures	Control miscalibration	Recalibrate control (see section on control recalibration)
	Optional Hi-limit setting	Hi-limit should be 10-25° higher than control set point
Excess surface temperature on door	Door seal deterioration	Replace door seal
Improper airflow	Fan motor failure	Replace fan motor
	Unbalanced fan wheel	Replace fan wheel
Excessive Vibration	Dirty fan wheel	Clean Fan
	Unbalanced fan wheel	Replace fan wheel
Oven will not control at set point	Hi-limit set too low	Set the hi-limit higher
	Hi-limit is out of calibration	Recalibrate the hi-limit (see directions on recalibrating the hi-limit)
	Control malfunction	Replace control
	Air friction of recirculation fan	Open exhaust air vent. Unit will not control below room ambient plus 45°C (81°F) with vent closed.
Heater does not shut off until the temperature reaches the hi-limit setting	Control malfunction	Replace control
	Relay malfunction	Replace relay

LAC1-10
120V-1PH-60HZ

LIST OF MATERIAL			
ITEM	PART NUMBER	QTY.	DESCRIPTION
CI	080822	1	61-06 CONTROL
HL	055143	1	H2 HI-LIMIT INSTRUMENT
1F	007456	1	A25X15A AMPTRAP FUSE
2F	007453	1	250 VOLT 6AMP FUSE
M	008333	1	1/25HP MOTOR
H	007773	1	1000 WATT HEATER
1CR	080187	1	20AMP RELAY
1LT	008657	1	AMBER PILOT LIGHT
2LT	019150	1	WHITE PILOT LIGHT
1.2SW	074116	2	SWITCH GRAY DPST
TRIAC	081482	1	TRIAC ASSEMBLY
POT	080734	1	SETPOINT POT ASSY.
1PB	030525	1	SETPOINT SWITCH ASSY.
C	031233	1	POWER CORD
T/C	051443	1	TYPE J THERMOCOUPLE

- CONTROL INSTRUMENT TERMINALS
- TERMINAL STRIP NUMBER
- PLUG TERMINAL NUMBER
- J1-5 YELLOW JUMPERS

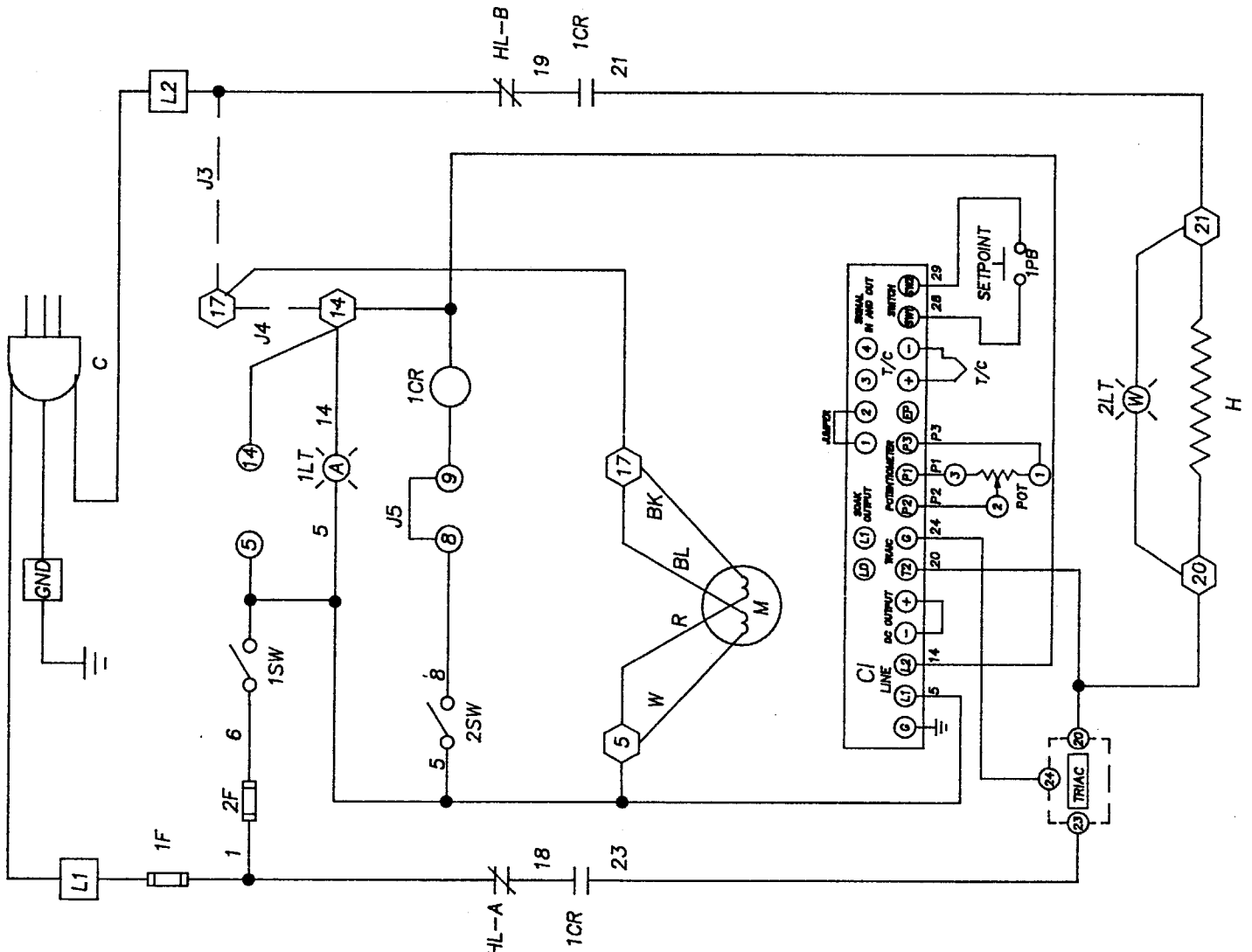

LAC1-38B
240V-1PH-60HZ

LIST OF MATERIAL			
ITEM	PART NUMBER	QTY	DESCRIPTION
CI	080822	1	61-06 CONTROL
HL	055143	1	H2 HI-LIMIT INSTRUMENT
1F	007456	1	A25X15A AMPTRAP FUSE
2F	007453	2	250 VOLT 6AMP FUSE
M	051805	1	1/4HP MOTOR
H	007775	1	1800 WATT HEATER
1CR	080187	1	20AMP RELAY
1LT	008657	1	AMBER PILOT LIGHT
2LT	008670	1	WHITE PILOT LIGHT
1,2SW	074116	2	SWITCH GRAY DPST
TRIAC	081482	1	TRIAC ASSEMBLY
POT	080734	1	SETPOINT POT ASSEMBLY
1PB	030525	1	SETPOINT SWITCH ASSEMBLY
C	105115	1	POWER CORD
CF	015229	1	MU3A1 240V FAN
T	012479	1	50VA TRANSFORMER
T/C	051443	1	TYPE J THERMOCOUPLE

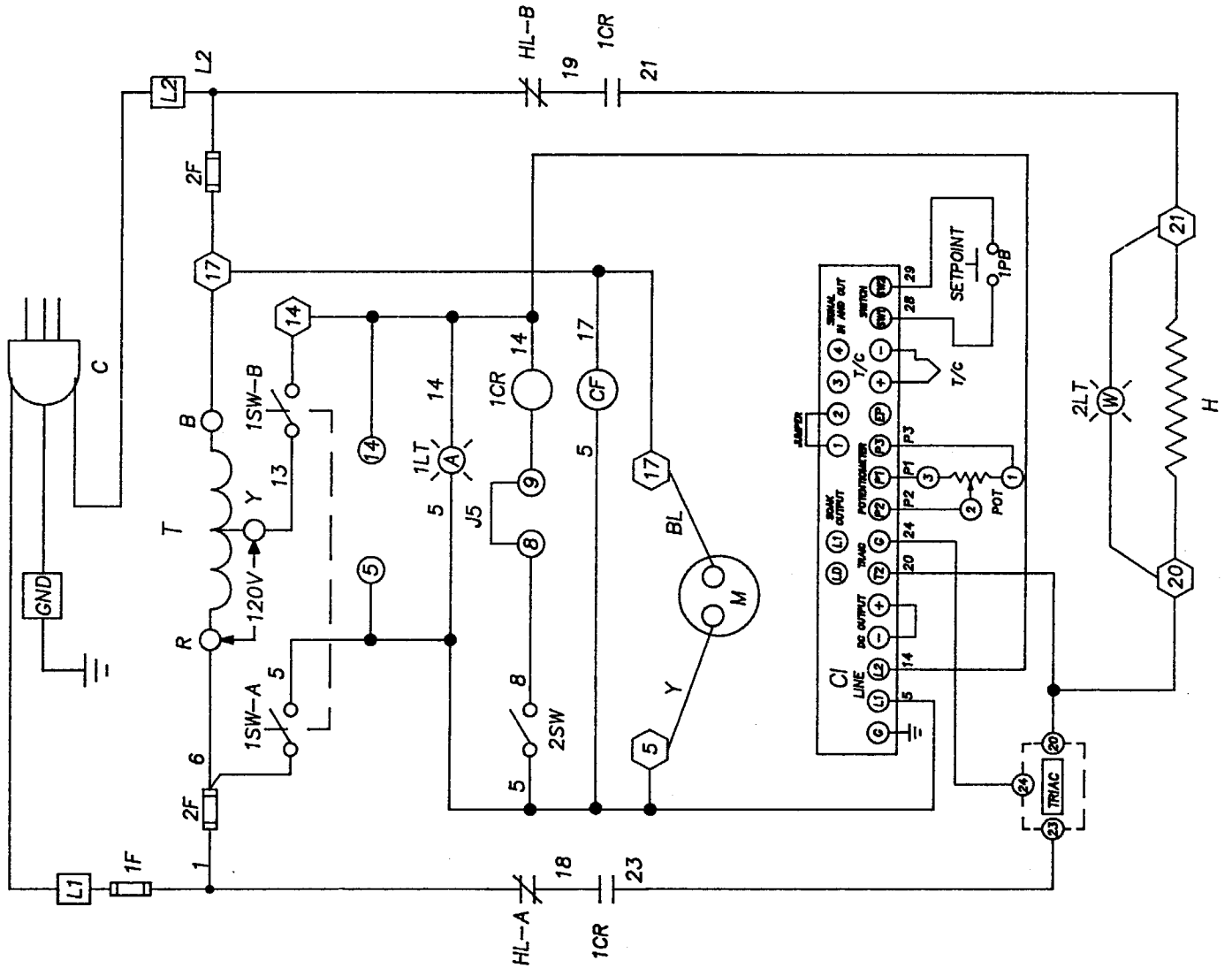
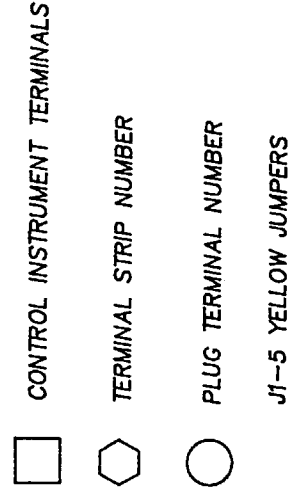

ELECTRICAL SCHEMATICS AND PARTS LIST FOR LAC OVENS

LIST OF MATERIAL

ITEM	PART NUMBER	QTY	DESCRIPTION
CI	080822	1	61-06 CONTROL
HL	055143	1	H2 HI-LIMIT INSTRUMENT
1F	007456	1	A25X15A AMPTRAP FUSE
2F	007453	2	250 VOLT 6AMP FUSE
M	051805	1	1/4HP MOTOR
H	007776	1	2400 WATT HEATER
1CR	080187	1	20AMP RELAY
1LT	008657	1	AMBER PILOT LIGHT
2LT	008670	1	WHITE PILOT LIGHT
1,2SW	074116	2	SWITCH GRAY DPST
TRIAC	081482	1	TRIAC ASSEMBLY
POT	080734	1	SETPOINT POT ASSEMBLY
1PB	030525	1	SETPOINT SWITCH ASSEMBLY
C	105115	1	POWER CORD
CF	015229	1	MU3A1 240V FAN
T	012479	1	50VA TRANSFORMER
T/C	051443	1	TYPE J THERMOCOUPLE

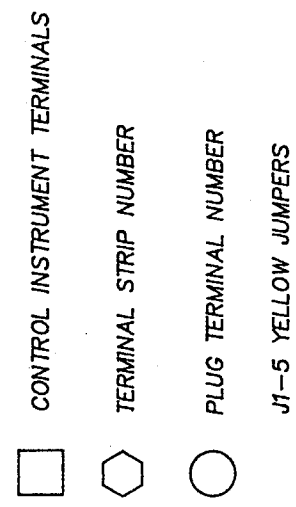

LAC1-67 240V-1PH-60HZ

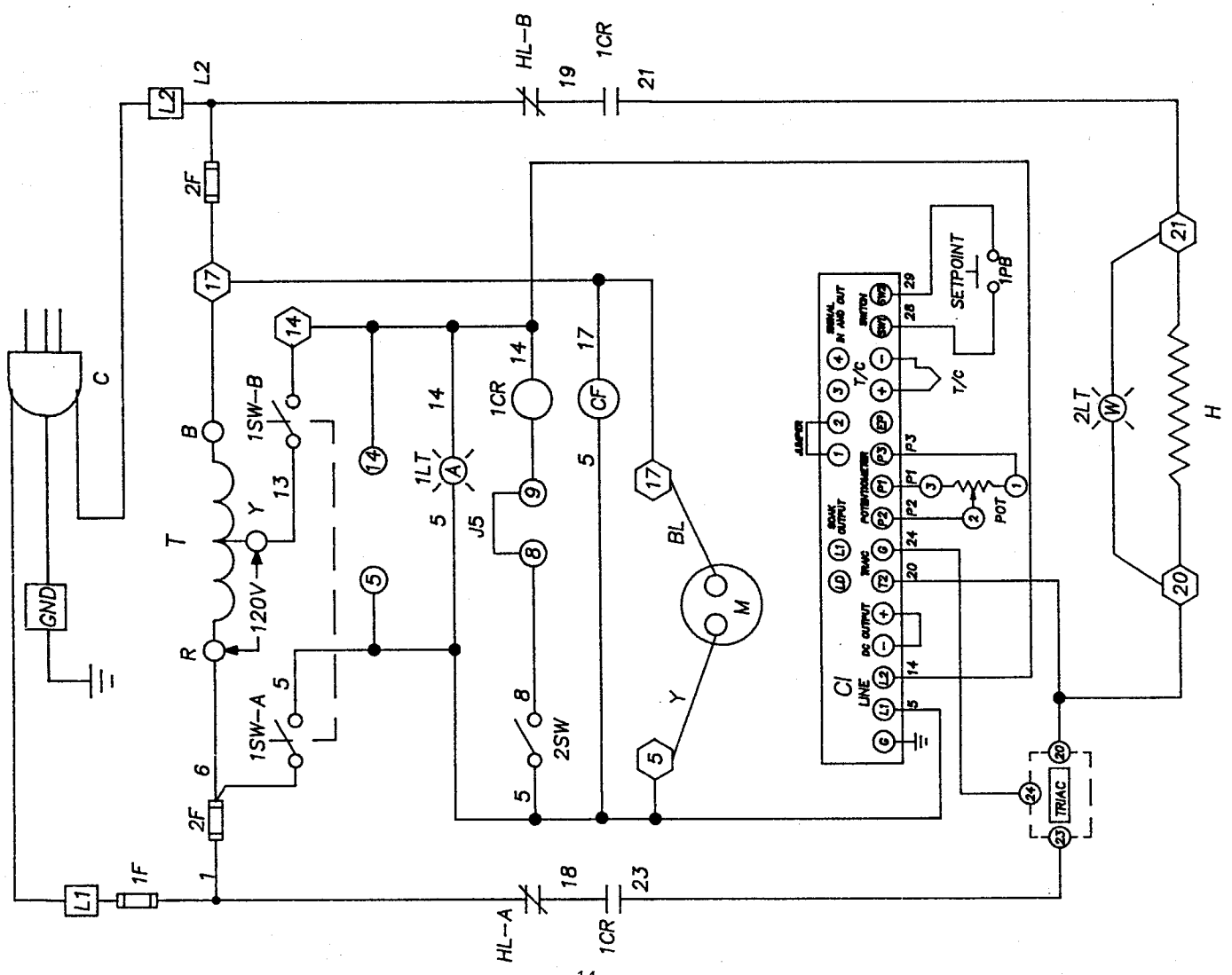

Industrial Equipment Commercial Warranty

Despatch Industries, Inc. warrants equipment manufactured by Despatch Industries, Inc., to be free from defects in workmanship and materials under normal use and service for a period of one (1) year from the date of delivery or the period of twenty-one hundred (2100) accumulated hours of use, whichever period is shorter.

Components manufactured by others, including but not limited to expendable items, are excluded from this warranty and are warranted (if at all) only in accordance with the warranty, if any, issued by such other manufacturer.

Use or service with corrosive or abrasive chemicals or materials is not deemed normal.

If Purchaser gives written notice specifying the particular defect or defects within 14 days after discovery thereof, Despatch Industries, Inc. will correct without charge any workmanship that is demonstrated to Despatch Industries, Inc. satisfaction to have been defective at time of installation or erection and will repair or replace, at the warrantor's option, without charge, f.o.b. Despatch Industries, Inc. factory, parts covered by this warranty that upon inspection are found defective under normal use within the warranty period above stated.

All work of removal and reinstallation or installation of parts, whether or not found defective, and shipping charges for defective or replacement parts shall be at the sole expense of Purchaser.

The foregoing warranty shall not apply to equipment repaired or altered by others, unless such repairs or alterations were specifically agreed to in writing by an officer of Despatch Industries, Inc.

Despatch Industries, Inc. shall not be liable for incidental or consequential damages of any kind (whether for personal injury, lost profits or otherwise), whether arising from breach of this warranty, negligence or other tort or otherwise, which occur during the course of installation of equipment, or which result from the use or misuse by user, its employees or others of the equipment supplied hereunder, or from any malfunction or nonfunction of such equipment, and Purchaser's sole and exclusive remedy against Despatch Industries, Inc. for any breach of the foregoing warranty or otherwise shall be for the repair or replacement of the equipment or parts thereof affected.

The foregoing warranty shall be valid and binding upon Despatch Industries, Inc. if and only if user loads, operates and maintains the equipment supplied hereunder in accordance with the instruction manual to be provided upon delivery of the equipment.

Despatch Industries, Inc. does not guarantee the process of manufacture by user or the quality of product to be produced by the equipment supplied hereunder and Despatch Industries, Inc. shall not be liable for lost profits.

THE FOREGOING WARRANTY IS EXCLUSIVE AND IN LIEU OF ALL OTHER EXPRESS AND IMPLIED WARRANTIES AND REPRESENTATIONS WHATSOEVER, INCLUDING BUT NOT LIMITED TO THOSE OF MERCHANTABILITY OR OF FITNESS FOR A PARTICULAR PURPOSE.

**Despatch Industries, Inc. • P.O. Box 1320 • Minneapolis, MN 55440-1320
612/331-1873 • Telex 29-0704 • Easy Link 6288-5512 • FAX 612/623-0257**

Despatch

787KP

PRINTED
IN
U.S.A.