

INSPIRED INNOVATION

Despatch
INDUSTRIES

PROTOCOL 3™ Controller OWNER'S MANUAL

E-105
PN 313327
VERSION 1
1/2012

SERVICE AND TECHNICAL SUPPORT

service parts: 1-800-473-7373
international service/main: 1-952-469-8230
service fax: 1-952-469-8193
service@despatch.com

GLOBAL HEADQUARTERS

phone: 1-952-469-5424
toll free usa: 1-888-337-7282
fax: 1-952-469-4513
sales@despatch.com
service@despatch.com

8860 207th Street West
Minneapolis, MN 55044 USA

Despatch
INDUSTRIES

MINNEAPOLIS • SHANGHAI • BERLIN • SINGAPORE • HSINCHU • TOKYO

Revision History

Revision	Date	Author	Description
1.0	1/2012	K. Livingston	Initial release

Copyright © 2012 by Despatch Industries.

All rights reserved. No part of the contents of this manual may be reproduced, copied or transmitted in any form or by any means including graphic, electronic, or mechanical methods or photocopying, recording, or information storage and retrieval systems without the written permission of Despatch Industries, unless for purchaser's personal use.

Table of Contents

1.	About This Manual	6
1.1.	Important User Information	6
1.2.	Manufacturer & Service.....	7
1.3.	Organization of this Manual	7
1.4.	Conventions	8
1.5.	Specifications	9
2.	Safety	13
2.1.	Safety Information	13
2.1.1.	Lockout.....	13
2.1.1.1.	Lockout Requirements.....	13
2.1.1.2.	Lockout Procedure with Despatch Products.....	13
2.2.	Maintenance.....	14
2.3.	Electrical Power	14
2.4.	Fire	14
2.5.	Equipment Lockout Requirements	15
3.	Theory of Operation.....	15
3.1.	System Control—In General.....	15
3.1.1.	High-Limit Function	15
3.2.	Outputs.....	16
4.	Assembly & Setup	18
4.1.	Install the Protocol 3 Controller.....	18
4.2.	Protocol 3 Controller Conversion with NO Options.....	19
5.	Working with Operating Modes	20
5.1.	User Controls	20
5.2.	Start-up Basics	23
5.3.	Manual Mode.....	23
5.3.1.	Start Manual Mode: Step by Step	24
5.4.	Timer Mode	25
5.5.	Profile Mode	26
5.6.	Main Menu.....	27
5.6.1.	Profile Setup.....	28
5.6.1.1.	Prepare for Profile Setup	30
5.6.1.2.	Sample Profile	31
5.6.1.3.	Entering the Sample Profile Setup.....	33
5.6.2.	Recorder Control	36
5.6.3.	USB Menu.....	37
5.6.3.1.	Working with USB Memory Stick Folders and Files.....	39
5.6.3.2.	File Naming Conventions.....	40
5.6.3.3.	Create a New Name Before Writing to the USB Device	40
5.7.	Configuration Menu.....	41
5.8.	Automatic Tuning	45
5.9.	Product Information	46
5.10.	Service Information.....	46
6.	Maintenance.....	47

6.1. Replacement Parts.....	47
7. Troubleshooting: Error Messages and Alarm.....	48
8. Appendices.....	49
8.1. Standard Products Warranty.....	49
8.2. Programming Worksheet.....	50

Figures

Figure 1. Operator Interface.....	15
Figure 2. Typical Controller Output Sticker.....	17
Figure 3. Protocol Plus to Protocol 3 Connection Conversions.....	19
Figure 4. Select a Mode Display.....	20
Figure 5. Manual Mode Display Screen.....	24
Figure 6. Timer Mode Display Screen.....	25
Figure 7. Profile Mode.....	26
Figure 8. Main Menu.....	27
Figure 9. Profile Setup.....	28
Figure 10. Profile Setup Menu.....	29
Figure 11. Sample Profile.....	31
Figure 12. Sample Profile Values.....	32
Figure 13. Recorder Control.....	36
Figure 14. Recorder Status.....	36
Figure 15. USB Menu.....	37
Figure 16. USB Port on Front Panel.....	39
Figure 17. USB Files and Folders Requirements (as seen from Windows Explorer).....	39
Figure 18. Configuration Menu (see also Table 14 for more information).....	42
Figure 19. Service Information Screen.....	46

Tables

Table 1. Process Input.....	9
Table 2. Outputs.....	10
Table 3. Operating Conditions (For indoor use).....	11
Table 4. Conformance Norms.....	11
Table 5. Display.....	11
Table 6. Data Recorder.....	12
Table 7. Protocol Plus to Protocol 3 Controller Conversion.....	19
Table 8. Keypad Buttons and Functions.....	21
Table 9. LEDs and Functions.....	22
Table 10. Sub Menu Descriptions.....	27
Table 11. Profile Setup Options.....	28
Table 12. Profile Parameter Options.....	35
Table 13. USB Menu Options.....	37
Table 14. Configuration Menu in Tabular Format.....	43
Table 15. Automatic Tuning Options.....	45

Copyright © 2012 by Despatch Industries.

All rights reserved. No part of the contents of this manual may be reproduced, copied or transmitted in any form or by any means including graphic, electronic, or mechanical methods or photocopying, recording, or information storage and retrieval systems without the written permission of Despatch Industries, unless for purchaser's personal use.

Table 16. Product Information Details.....	46
Table 17. Error Messages and Next Steps.	48
Table 18. Programming Worksheet.	50

Copyright © 2012 by Despatch Industries.

All rights reserved. No part of the contents of this manual may be reproduced, copied or transmitted in any form or by any means including graphic, electronic, or mechanical methods or photocopying, recording, or information storage and retrieval systems without the written permission of Despatch Industries, unless for purchaser's personal use.

1. About This Manual

1.1. Important User Information

Copyright © 2011 by Despatch Industries.

All rights reserved. No part of the contents of this manual may be reproduced, copied, or transmitted in any form or by any means including graphic, electronic, or mechanical methods or photocopying, recording, or information storage and retrieval systems without the written permission of the publisher, unless it is for the purchaser's personal use.

Printed and bound in the United States of America.

The information in this manual is subject to change without notice and does not represent a commitment on the part of Despatch Industries. Despatch Industries does not assume any responsibility for any errors that may appear in this manual.

In no event will Despatch Industries be liable for technical or editorial omissions made herein, nor for direct, indirect, special, incidental, or consequential damages resulting from the use or defect of this manual.

	<p><i>Values displayed on screens are examples only. Though those values may be typical, contact Despatch Industries for the final value.</i></p>
---	--

	<p><i>Users of this equipment must comply with operating procedures and training of operation personnel as required by the Occupational Safety and Health Act (OSHA) of 1970, Section 6 and relevant safety standards, as well as other safety rules and regulations of state and local governments. Refer to the relevant safety standards in OSHA and National Fire Protection Association (NFPA), section 86 of 1990.</i></p>
---	---

Copyright © 2012 by Despatch Industries.

All rights reserved. No part of the contents of this manual may be reproduced, copied or transmitted in any form or by any means including graphic, electronic, or mechanical methods or photocopying, recording, or information storage and retrieval systems without the written permission of Despatch Industries, unless for purchaser's personal use.

	<p><i>Danger!</i></p> <p><i>Only fully-trained and qualified personnel should setup and maintain this equipment. Improper setup and operation of this equipment could cause an explosion that may result in equipment damage, personal injury or possible death.</i></p>
---	--

The information in this document is not intended to cover all possible conditions and situations that might occur. The end user must exercise caution and common sense when installing or maintaining Despatch Industries products. If any questions or problems arise, call Despatch Industries at 1-888-DESPATCH or 1-952-469-5424.

1.2. **Manufacturer & Service**

Despatch has specialized in thermal processing for over 100 years. Technical expertise gained over those years helps provide innovative solutions to critical applications in vertical markets and cutting edge technology worldwide. Despatch products are backed by a drive for long-term customer satisfaction and a strong sense of responsibility. The worldwide network of factory-trained Service Professionals is available to support your Despatch equipment. From full service preventive maintenance to routine repair and certified calibration and uniformity, the Despatch service network is positioned to respond to your business needs. Our service programs are customized to meet your specific needs using our Advantage Service Assurance Program (ASAP). For more information on ASAP, visit www.despatch.com.



Global Headquarters	Contact	Service & Technical Support
Despatch Industries 8860 207th Street Lakeville, MN 55044 USA	International/Main: 1-952-469-5424 US toll free: 1-888-337-7282 Fax: 1-952-469-4513 info@despatch.com www.despatch.com	Service: 1-952-469-8230 US toll free: 1-800-473-7373 Service @despatch.com

1.3. **Organization of this Manual**

This owner's manual contains the most comprehensive set of information for the Despatch Protocol 3™ controller, including installation instructions, theory of operation, operating instructions, among other things.

	<p><i>Danger!</i></p> <p><i>Failure to heed warnings in this instruction manual and on the oven could result in personal injury, property damage or death.</i></p>
---	---

1.4. Conventions

	<p><i>This icon signifies information that describes an unsafe condition that may result in death, serious injury, or damage to the equipment.</i></p>
<p>Danger!</p>	<p><i>Danger is the signal word used to indicate a hazardous situation that, if not avoided, will result in death or severe injury.</i></p>
<p>Warning!</p>	<p><i>Warning is the signal word used to indicate a hazardous situation that, if not avoided, could result in death or severe injury.</i></p>
<p>Caution!</p>	<p><i>Caution is the signal word used to indicate a hazardous situation that, if not avoided, could result in moderate or minor injury.</i></p>
<p>Notice</p>	<p><i>Notice is the signal word used to indicate a hazardous situation that, if not avoided, could result in property damage.</i></p>
	<p><i>This icon signifies supplemental important information.</i></p>
<p>LOG OUT</p>	<p><i>Bold, 10 point sans-serif typeface indicates a specific key or button on screen to click.</i></p>

Copyright © 2012 by Despatch Industries.

All rights reserved. No part of the contents of this manual may be reproduced, copied or transmitted in any form or by any means including graphic, electronic, or mechanical methods or photocopying, recording, or information storage and retrieval systems without the written permission of Despatch Industries, unless for purchaser's personal use.

1.5. Specifications

Specifications for the Protocol 3 controller include six sets of information:

- Process Input (Table 1)
- Outputs (Table 2)
- Operating Conditions (Table 3)
- Conformance Norms (Table 4)
- Display (Table 5)
- Data Recorder (Table 6)

Table 1. Process Input.

Item	Description		
Sampling Rate:	4 per second		
Resolution:	16 bits. Always four times better than display resolution.		
Impedance:	>10M Ω resistive, except DC mA (5 Ω) and V (47k Ω)		
Temp Stability:	Error <0.01% of span per °C change in ambient temperature		
Supply Variation:	Supply voltage influence negligible within supply limits		
Humidity Influence:	Negligible if non-condensing		
Process Display:	Displays up to 5% over and 5% under span limits		
Process Variable Input Offset:	Reading adjustable \pm Controller Span. Values added to Process Variable, Values subtracted from Process Variable.		
Sensor Break Detection:	<ul style="list-style-type: none"> • Thermocouple & RTD—SSR output goes to 0 • High Limit Sensor Break alarms activate • Linear (4 to 20mA, 2 to 10V and 1 to 5V only)—SSR output goes to 0 		
Isolation:	Isolated from all outputs (except SSR driver) at 240V AC		
Supported Thermocouple Types & Ranges:	Type	Range °C	Range °F
	B	+100 to 1824°C	+211 to 3315°F
	C	0 to 2320°C	32 to 4208°F
	D	0 to 2315°C	32 to 4199°F
	E	-240 to 1000°C	-400 to 1832°F
	J	-200 to 1200°C	-328 to 2192°F *
	K	-200 to 1200°C	-328 to 2192°F *
	L	0 to 762°C	32 to 1402°F *
	N	0 to 1399°C	32 to 2551°F *
	PtRh	0 to 1850°C	32 to 3362°F
20%: 40%			

Copyright © 2012 by Despatch Industries.

All rights reserved. No part of the contents of this manual may be reproduced, copied or transmitted in any form or by any means including graphic, electronic, or mechanical methods or photocopying, recording, or information storage and retrieval systems without the written permission of Despatch Industries, unless for purchaser's personal use.

Item	Description		
	R	0 to 1759°C	32 to 3198°F
	S	0 to 1762°C	32 to 3204°F
	T	-240 to 400°C	-400 to 752°F *
	Optional decimal place can be displayed up to 999.9°C/F		
Thermocouple Calibration:	±0.1% of full range, ±1LSD (±1°C for internal CJC if enabled). Linearization better than better ±0.2°C (±0.05 typical) on ranges marked * in the table above. Linearization for other ranges is better than ±0.5°C. BS4937, NBS125 & IEC584.		
Supported RTD Types & Ranges:	Type	Range °C	Range °F
	3-Wire PT100	-199 to 800°C	-328 to 1472°F
	NI120	-80 to 240°C	-112 to 464°F
	Optional decimal place can be displayed up to 999.9°C/F		
RTD Calibration:	0.1% of full range, ±1LSD		
Linearization:	Linearization better than ±0.2°C (±0.05 typical). PT100 input to BS1904 & DIN43760 (0.00385Ω/°C).		
RTD Excitation:	Sensor current 150µA ±10%		
Lead Resistance:	<0.5% of span error for max 50Ωper lead, balanced		
Supported Linear Types & Ranges:	Type	Range	Offset Range
	mA DC	0 to 20mA DC	4 to 20mA DC
	mV DC	0 to 50mV DC	10 to 50mV DC
	V DC	0 to 5V DC	1 to 5V DC
	V DC	0 to 10V DC	2 to 10V DC
	Scalable from -9999 to 10000. Decimal point selectable from 0 to 3 places, but limited to 5 display digits (e.g. 9999.9)		
Maximum Overload:	1A on mA input terminals, 30V on voltage input terminals		
DC Calibration:	±0.1% of full range, ±1LSD		
DC Input Multi-Point Linearization:	Up to 15 scaling values can be defined anywhere between 0.1 and 100% of input		

Table 2. Outputs.

Item	Description
Relays	
Type & Rating:	Single pole single throw (SPST); 2A resistive at 120/240VAC
Lifetime:	>200,000 operations at rated voltage/current

Copyright © 2012 by Despatch Industries.

All rights reserved. No part of the contents of this manual may be reproduced, copied or transmitted in any form or by any means including graphic, electronic, or mechanical methods or photocopying, recording, or information storage and retrieval systems without the written permission of Despatch Industries, unless for purchaser's personal use.

Item	Description
Isolation:	Basic Isolation
Linear DC	
Resolution:	8 bits in 250mS (10 bits in 1s typical, >10 bits in >1s typical)
Accuracy:	±0.25% of range, (mA @ 250W, V @ 2kW). Degrades linearly to ±0.5% for increasing burden (to specification limits)
Isolation:	Basic Isolation

Table 3. Operating Conditions (For indoor use).

Item	Description
Temperature:	<ul style="list-style-type: none"> Operating: 0°C to 55°C (32°F to 131°F) Storage: -20°C to 80°C (-4°F to 176°F)
Relative Humidity:	20% to 95% non-condensing
Supply Voltage and Power:	100 to 240VAC ±10%, 50/60Hz, 20VA

Table 4. Conformance Norms.

Item	Description
EMI:	CE: Complies with EN61326
Safety Considerations:	CE: Complies with EN61010-1. UL, cUL to UL61010C-1. Pollution Degree 2, Installation Category II
Front Panel Sealing:	IP65 rating. IP20 behind the panel. (IP rating not recognized / approved by UL)
Front Panel Cleaning:	Wash with warm soapy water and dry immediately. Close the USB cover (if fitted) before cleaning.

Table 5. Display.

Item	Description
Display Type:	160 x 80 pixel, monochrome graphic LCD with a dual color (red/green) backlight
Display Area:	66.54mm (W) x 37.42mm (H)
Display Characters:	0 to 9, a to z, A to Z, plus () - and _

Table 6. Data Recorder.

Item	Description
Recording Memory:	1Mb non-volatile flash memory. Data retained when power is turned off
Recording Interval:	1; 2; 5; 10; 15; 30 seconds or 1; 2; 5; 10; 15; 30 minutes
Recording Capacity:	Dependant on sample rate and number of values recorded. Two values can be recorded for up to 7 days at 10s intervals. More values or faster sample rates deduce the maximum duration.
RTC Battery Type:	VARTA CR 1616 3V Lithium. Clock runs for >1 year without power (Part # 274030)
RTC accuracy:	Real Time Clock error <1 second per day

2. Safety

2.1. Safety Information

Do not work on the Protocol 3 controller without reading and understanding this section which contains important information and warnings. Ignoring these warnings can result in death, serious injury or damage to the machine and product.

2.1.1. Lockout

Machine lockout places the Protocol 3 controller into a zero energy state and prevents accidental machine start up. Always follow the Lockout Procedure described in this Section before cleaning, maintaining or repairing the Protocol 3 controller. An accidental start-up, while working on the Protocol 3 controller, can result in serious injury or death.

2.1.1.1. Lockout Requirements

1. Every power source that can energize any element of the Protocol 3 controller must be shut off at the closest possible power source. This includes air, water, nitrogen and electricity, including the Disconnect Switch.
2. After energy sources are locked out, test to ensure circuits are de-energized.

2.1.1.2. Lockout Procedure with Despatch Products

Personnel authorized to lockout equipment must have the necessary locks to perform the lockout.

1. Physically disconnect all electrical power to the machine or lockout (with a padlock) the appropriate breaker or disconnects.
2. Close all valves and bleed off any pressure.
3. Test for power by attempting a start with the machine controls.
4. Identify the Lockout Condition with a tag on the electrical disconnect and pneumatic shut off valves.
5. When work is complete, remove all tags and restore the machine to its working state.



Danger!

Electrical panels contain high voltage. Disconnect and lock out the power supply before working inside any electrical panels. Failure to lock out the power supply will result in death or injury.

2.2. Maintenance

Only qualified and trained personnel should perform maintenance or repair.

2.3. Electrical Power

Only qualified and trained personnel should perform electrical maintenance or electrical repair.

	<p><i>Danger!</i></p> <p><i>Contact with energized electrical sources will result in serious injury or death.</i></p>
---	---

- Before performing maintenance, disconnect all electrical power from the machine. Use a padlock and lockout all disconnects feeding power to the machine.
- Never clean or repair the controller when in operation.
- Unauthorized alterations or modifications to Protocol 3 controller are strictly forbidden. Never modify any electrical circuits. Unauthorized modifications can impair the function and safety of the Protocol 3 controller.

2.4. Fire

Keep the Protocol 3 controller clean and free of scrap materials, oil or solvents to prevent the possibility of fire. In the event of fire, use a fire extinguisher as follows.

1. De-energize the machine immediately by pushing an Emergency Stop push button (if supplied).
2. Turn off the remote main disconnect (customer supplied disconnect).
3. If the fire is in the workspace, keep the door closed.
4. Extinguish the fire.

	<p><i>Danger!</i></p> <p><i>Always disconnect all power before extinguishing a fire. Attempting to extinguish a fire in a machine connected to electrical power will result in serious injury or death.</i></p>
---	---

2.5. **Equipment Lockout Requirements**

To prevent injury or equipment damage during inspection or repair, the Protocol 3 controller must be locked out.

3. **Theory of Operation**

The Protocol 3 is a microprocessor based digital temperature controller designed for simple and flexible oven operation (Figure 1). The Protocol 3 controller operates as a dual-functioning controller/high limit instrument. The control portion utilizes a time-proportioning voltage signal to control heating devices with minimal temperature fluctuations.

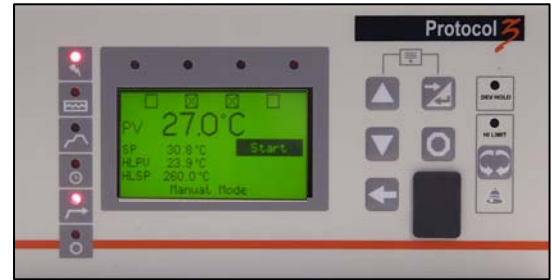

Figure 1. Operator Interface.

The high limit portion protects the product and/or the oven from overheating. If the product being processed has a critical high temperature limit, the high limit setpoint should be set to a temperature somewhat below the temperature at which the product could be damaged. If the product does not have a critical high temperature limit, the high limit setpoint should be set 5 to 15 degrees higher than the maximum programmed setpoint at which the oven will operate.

The Protocol 3 controller provides three primary operating modes:

- **Manual:** Oven operates continuously at a fixed temperature until turned off.
- **Timer:** Oven operates at a fixed temperature for a user-selected time period, and then automatically turns off.
- **Profile:** Temperatures increase or decrease as defined by 255 segments that can be allocated to 64 ramp and soak profiles. The profiles can be linked to provide additional temperature combinations.

3.1. **System Control—In General**

- The Protocol 3 controller provides outputs for the cooling fan, door lock switch/door release pushbutton, and optional beacon light
- A number of profiles for oven heating cycles are stored in the Protocol 3 controller. Access profiles using the Protocol 3 keypad
- The Protocol 3 controls the solenoid valves in an inert atmosphere oven for purge, maintain and water cooling operation

3.1.1. **High-Limit Function**

The Protocol 3 controller has an integrated high limit function which disables the heater output when tripped. The High-Limit temperature is displayed as HLPV (Manual Mode only).

Copyright © 2012 by Despatch Industries.

All rights reserved. No part of the contents of this manual may be reproduced, copied or transmitted in any form or by any means including graphic, electronic, or mechanical methods or photocopying, recording, or information storage and retrieval systems without the written permission of Despatch Industries, unless for purchaser's personal use.

If the high limit trips, the Hi-Limit indicator will light and the relay must be manually reset. Allow the oven to cool several degrees below the setpoint (or increase the high limit setpoint) and then press . The indicator will turn off.

3.2. Outputs

The Protocol 3 controller comes standard with an output signal that can transmit temperature data, setpoint data or control power to a user-supplied recording device. Output relays (five) can also signal user-specified events or alarm to external devices (Figure 2 and Figure 3).

- **Heating output:** The control output is a DC voltage open-collector output which is time-proportioned and designed to control a heat control device such as a solid state relay.
- **High limit:** The high limit output is a SPDT relay which is energized under normal operating conditions. If the control senses a temperature higher than the high limit setpoint, or if there is a sensor error, the high limit relay will de-energize until the condition is cleared and **Reset** is pressed. When the high limit relay is de-energized, the heater is disabled.
- **Retransmission:** The retransmission output is a signal that is proportional to the process temperature, setpoint or control power:
 - 0-5V
 - 0-10V
 - 2-10V
 - 0-20 ma
 - 4-20 ma
 - 0-10VDC Power Supply

The signal can be an input to other devices such as a chart recorder.

- **Relays:** The five SPST dry contact relay outputs can be configured to function as alarms, events, or end of cycle. These outputs can be utilized in Manual, Timer or Profile Modes.



PRL: **BT** **MADE IN UK**
D.O.M: **0711**

MODEL: VE65L41E5
SERIAL No :123456 001 026







MODEL: VE65L41E5
SERIAL No:123456 001 026

MADE IN UK
D.O.M: 0711 PRL: **BT**

POWER RATING 100-240VAC 50/60Hz 11VA ALL RELAY CONTACTS 2A RESISTIVE 120-240VAC USE COPPER CONDUCTORS (EXCEPT ON T/C INPUT)

	AC POWER	RELAY1	RELAY2	RELAY3	RELAY4	RELAY5	Linear Output	PROC INPUT	RS485 Comms	Digital Inputs	SSR Output	HI Limit Output	HI Lim Input
	L N G	NO C	NO C	NO C	NO C	NO C	+ -	- mA + + V/mV - + TIC -	- + C	1 2 3 4	+ -	NO COM NC	- mA + + V/mV - + TIC -
	1 2 3	4 5	6 7	8 9	10 11	12 13	14 15	16 17 18	19 20 21	22 23 24 25	26 27	28 29 30	31 32 33

Figure 2. Typical Controller Output Sticker.

Copyright © 2012 by Despatch Industries.

All rights reserved. No part of the contents of this manual may be reproduced, copied or transmitted in any form or by any means including graphic, electronic, or mechanical methods or photocopying, recording, or information storage and retrieval systems without the written permission of Despatch Industries, unless for purchaser's personal use.

4. Assembly & Setup

	<p><i>Danger!</i></p> <p><i>All grounding and safety equipment must be in compliance with applicable codes, ordinances and accepted safe practices.</i></p>
---	--

	<p><i>Warning!</i></p> <p><i>Disconnect the main power switch or power cord before attempting any repair or adjustment.</i></p>
---	--

4.1. Install the Protocol 3 Controller

When replacing a Protocol 3 controller, follow the steps below. Tools required for installation include ¼" socket set with #1 bit, #2 Philips screwdriver.

1. Disconnect the power.
2. Unplug all terminals on the rear of the control, noting the proper connections (Figure 3).
3. Remove the retaining clips for the controller.
4. Remove the controller.
5. Insert the new controller into the panel.
6. Fasten the retaining clips.
7. Re-plug all terminals.
8. Secure the control panel.

4.2. Protocol 3 Controller Conversion with NO Options

To replace the older model Protocol Plus controller with the newer Protocol 3 controller, connect terminal blocks as indicated in Table 7 and Figure 3.

Table 7. Protocol Plus to Protocol 3 Controller Conversion.

Terminal Block	Former Protocol Plus Connections	New Protocol 3 Connections
Three pin terminal block for power leads	Terminals 30, 31, 32	Terminals 1, 2, 3
Five pin terminal block for SSR and Hi-limit	Terminals 17, 18, 19, 20, 21	Terminals 26, 27, 28, 29, 30
Remove the four-pin terminal block from thermocouples and rewire with two three-pin blocks.	Control Thermocouple Terminals 13, 14	Control Thermocouple Terminals 17, 18
	Hi-limit Thermocouple Terminals 15, 16	Hi-limit Thermocouple Terminals 32, 33

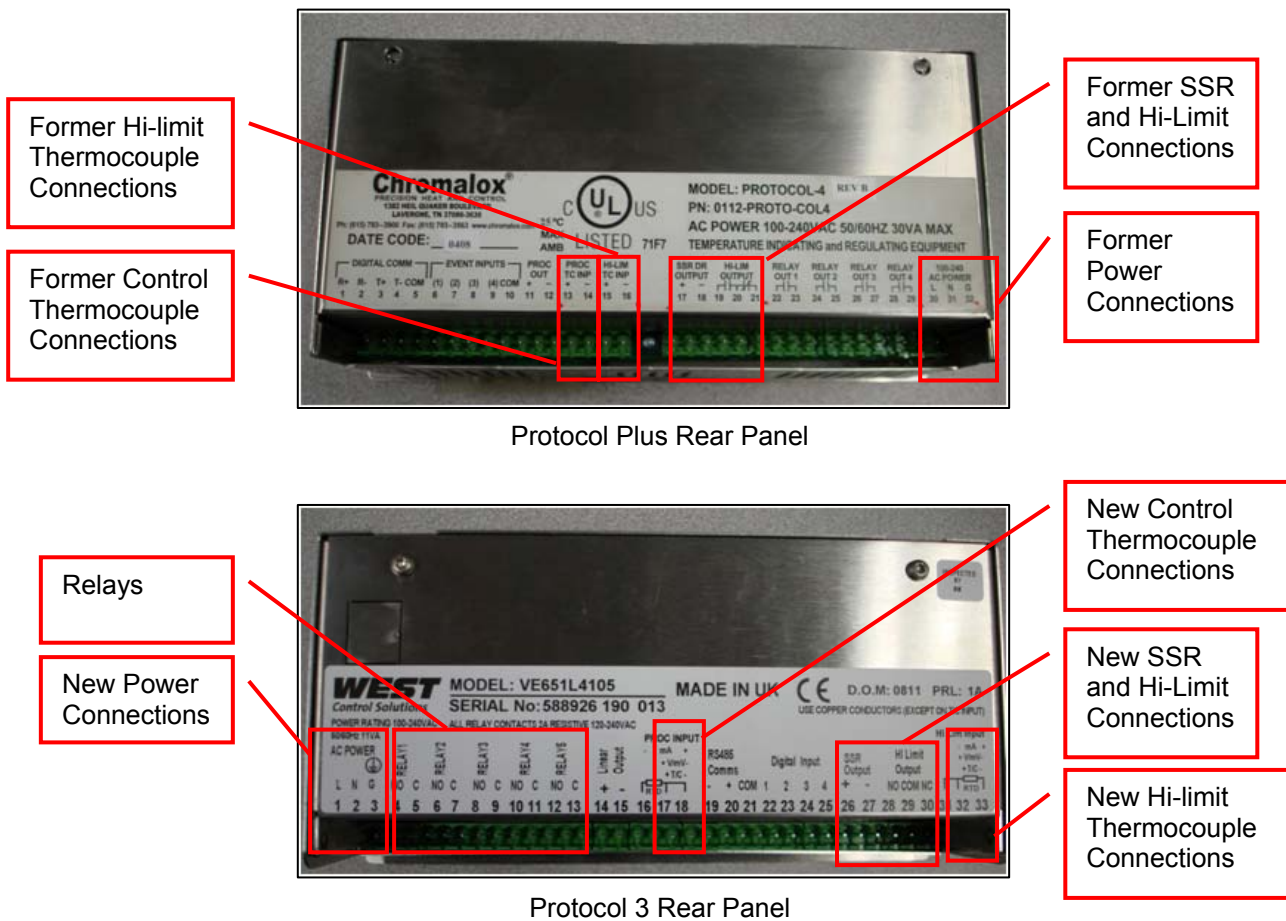



Figure 3. Protocol Plus to Protocol 3 Connection Conversions.

Copyright © 2012 by Despatch Industries.

All rights reserved. No part of the contents of this manual may be reproduced, copied or transmitted in any form or by any means including graphic, electronic, or mechanical methods or photocopying, recording, or information storage and retrieval systems without the written permission of Despatch Industries, unless for purchaser's personal use.



5. Working with Operating Modes

	<p><i>Users and operators of this controller must comply with operating procedures and training of operating personnel as required by the Occupational Safety and Health Act (OSHA) of 1970, Section 5 and relevant safety standards, and other safety rules and regulations of state and local governments. Refer to the relevant safety standards in OSHA and National Fire Protection Association (NFPA), Section 86 of 1990.</i></p>
---	---

5.1. User Controls

Each Protocol 3 Controller has six keypad switches (Table 8). Use the buttons to navigate user menus, adjust parameter values and control outputs. In configuration screens, a context sensitive scrolling help-text displays user-guides about the function of the keys across the bottom of the screen.

The Protocol 3 Controller has nine LEDs which indicate a variety of instrument functions (Table 9).

When the Protocol 3 Controller is first powered ON, the screen displays Select a Mode (Figure 4). Use  and  to navigate and  to select the highlighted mode.

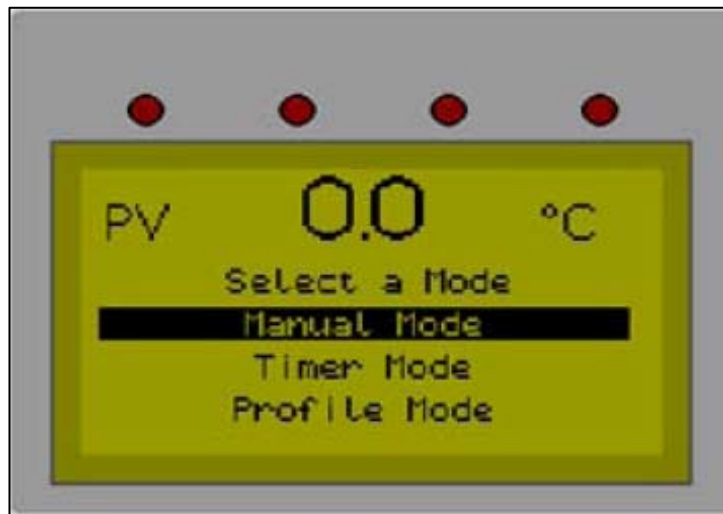









Figure 4. Select a Mode Display.

Table 8. Keypad Buttons and Functions.

Keypad Button	Function
	<p>Navigate to previous screen Press to move back to the previous parameter or screen in the current mode.</p>  <p>NOTE: Pressing this switch updates the instrument to the value displayed. If editing a parameter, ensure the current (highlighted) parameter value is correct before pressing.</p>
	<p>Navigate down through menu/parameter lists</p> <ul style="list-style-type: none"> • Menus and configuration choice screens: Press to move to the next item on the list. • Editable values: Press to decrease. Press and hold to speed the change. • Trend View: press to move the Cursor Line back through stored data points.
	<p>Navigate up through menu/parameter lists</p> <ul style="list-style-type: none"> • Menus and configuration choice screens: Press to move to the previous item on the list. • Editable values: Press to increase. Press and hold to speed the change. • Trend View: press to move the Cursor Line forward through stored data points.
	<p>Navigate to next item on a screen or to next screen</p> <ul style="list-style-type: none"> • Press to move forward to the next parameter or screen in the current mode. • Enables Edit on parameters in the Main Mode selections.  <p>NOTE: Pressing this switch updates the instrument to the value displayed. If editing a parameter, ensure the current (highlighted) parameter value is correct before pressing.</p>
	<p>Manual, Timer and Profile Mode: press to stop current process</p> <ul style="list-style-type: none"> • In Manual Mode, pressing switch disables the controlling output • In Timer Mode, pressing switch stops timer and disables controlling output • In Profile Mode, pressing switch stops current profile and disables controlling output













Keypad Button	Function
	<p>Reset Latched High Limit relay if below alarm condition If High Limit alarm is active, press to release the High Limit relay.</p> <p style="text-align: center;"></p> <p>NOTE: This switch releases the High Limit relay only if the controller is not in the High Alarm State (LED indicator turned OFF).</p>
	<p>Simultaneously press  and  to move up one menu level:</p> <ul style="list-style-type: none"> • From Select a Mode, pressing both moves to the main menu. • From Sub-menus, press both several times to reach the main menu. <p style="text-align: center;"></p> <p>NOTE: Simultaneously pressing these switches updates the instrument to the value displayed. If editing a parameter, ensure the current (highlighted) parameter value is correct before pressing.</p>

Table 9. LEDs and Functions.

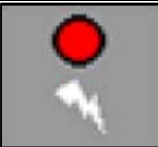
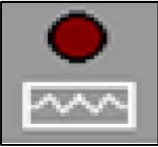
LED	Function
	Power LED: When lit, indicates power to the device.
	Heater LED: When lit, indicates primary heating output is active.
	Profile LED: When lit, indicates a profile is currently running.
	Timer LED: When lit, indicates a timer is currently running.

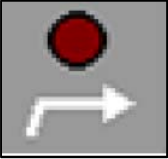
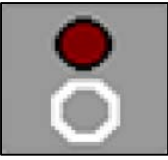
LED	Function
	Manual LED: When lit, indicates the controller is in Manual Mode.
	Cycle Complete LED: When lit, indicates the controller is currently stopped.
	When lit during a profile or Timer Mode, indicates process value has deviated from the soak value indicated by the controller. Set Soak Deviation value in the Profile Configuration mode or in the Timer Mode from the Main Menu. See Troubleshooting Section 7 for more information.
	When lit indicates the controller has exceeded the High Limit Value. Set High Limit Alarm Value and Hysteresis in the Alarm Configuration menu.
 (Four LEDs located above LCD display)	When lit, indicates relays 1-4 are active. Relay can be assigned as an Event, Alarm or Cycle.





5.2. Start-up Basics

	Change configuration controls depending on the mode used. Refer to the specific operating instructions below, for more information.
---	--

At initial power-up, control is in **Select a Mode**. This screen allows the choice of manual mode, timer mode or profile mode.

5.3. Manual Mode

Manual Mode is a single set point control (Figure 5). Use Manual Mode to control Set Point, High Limit Value and four relays.

Press  or  to navigate,  to select the highlighted option. Press  to exit from **Manual Mode** and  to stop all outputs.

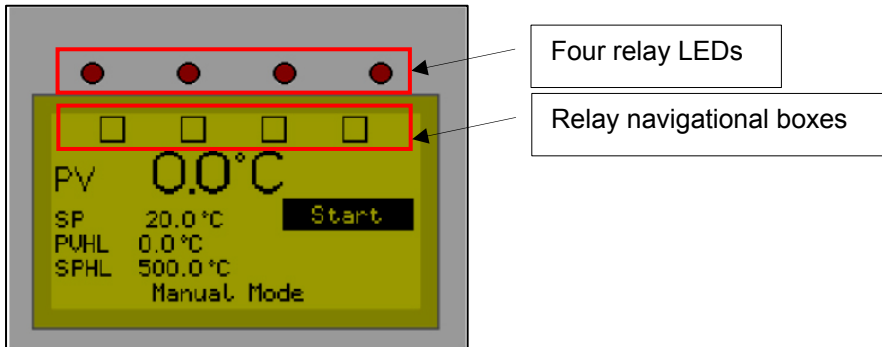



























Figure 5. Manual Mode Display Screen.

5.3.1. Start Manual Mode: Step by Step

1. Navigate to and highlight **Manual Mode**.
2. Press  to display **Manual Mode**.
3. Manual Mode allows you to set the setpoint (SP), and the High Limit set point (HLSP).
 - a. Press  or  to navigate through the menu.
 - b. Select and highlight the menu item.
 - c. Press .
 - d. Press  or  to change values
 - e. Press  to select the value.
4. Manual Mode allows you to set event relay status
 - a. Press  or  to navigate to and select the appropriate relay (Figure 5).
 - b. Press  to toggle the relay on and off.
5. Once all parameters are set, press  or  to navigate to and highlight **Start**.
6. Press  to start the process.
 - a. Press  to abort the process.
 - b. After pressing , press  to return to **Select a Mode** screen
7. Adjust the temperature setpoint while running in Manual or Timer Mode by:
 - a. Press .
 - b. Press  or  to select mode of operation.















Copyright © 2012 by Despatch Industries.

All rights reserved. No part of the contents of this manual may be reproduced, copied or transmitted in any form or by any means including graphic, electronic, or mechanical methods or photocopying, recording, or information storage and retrieval systems without the written permission of Despatch Industries, unless for purchaser's personal use.

- c. Press .
 - d. Press  or  to change the SP value.
 - e. Press .
 - f. Press .
8. return to Stopped Mode at any time, press  and the Cycle Complete LED will illuminate Press  to select a mode screen.

5.4. Timer Mode

Use **Timer Mode** to control Time Set Point: when the time expires, the control output is turned OFF (Figure 6).

1. Navigate to and highlight **Timer Mode**.
2. Press  or  to navigate to the desired time or temperature units.
3. Press  to select the value to change.
4. Press  or  to change value.
5. Press  to enter the desired value.
6. **Timer Mode** allows you to set event relay status:
 - a. Press  or  to navigate to and select the appropriate relay (Figure 5).
 - b. Press  to toggle the relay ON and OFF.
7. Set all parameters then press  or  to navigate to and highlight **Start**.
8. Press  to start the process.
 - a. Press  to abort the process
 - b. Press  to return to **Select a Mode** screen.
9. Adjust the temperature setpoint while running in **Manual Mode** or **Timer Mode** by:
 - a. Press .

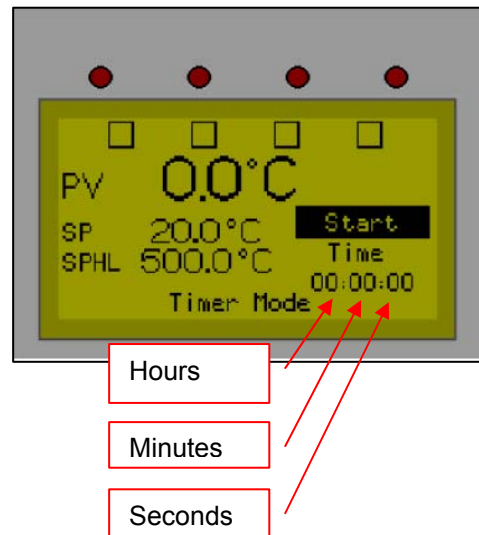

















Figure 6. Timer Mode Display Screen.

- b. Press  or  to navigate to the desired time or temperature units.
 - c. Press .
 - d. Press  or  to change the SP value.
 - e. Press .
 - f. Press  to return to normal display.
10. To return to **Stopped Mode** at any time, press  and the Cycle Complete LED will illuminate.
11. Press  to return to **Select A Mode** screen.

5.5. Profile Mode

Navigate to HLSP to set the High Limit Setpoint before running a profile. Use Profile Mode to select and run profiles that are programmed into the unit (Figure 7). Press  or  to navigate,  to select the highlighted profile. Press  to start profile. Press  to stop the profile and  to exit Profile Mode (profile must be stopped to exit Profile Mode).

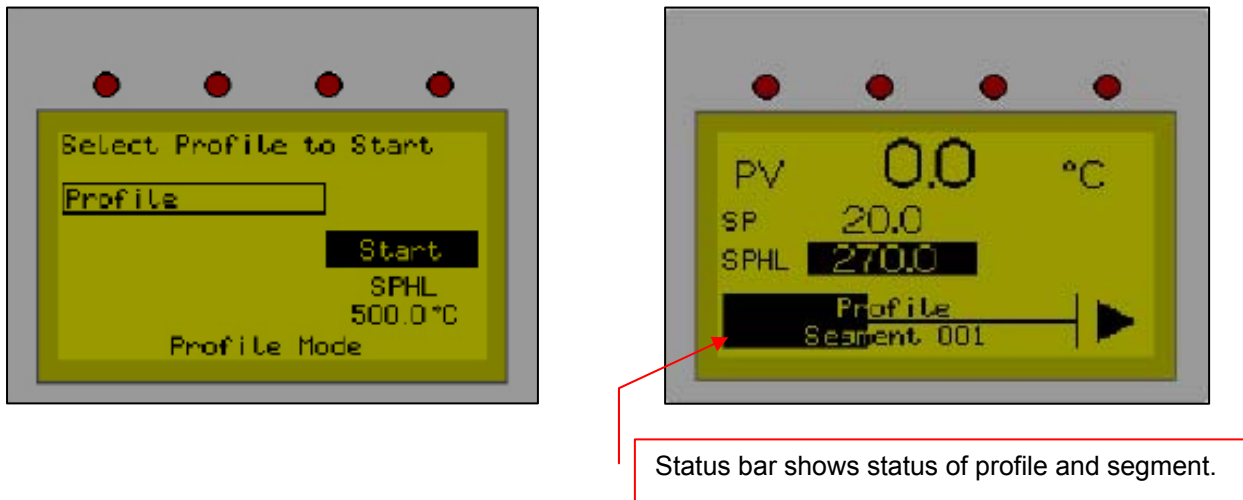

Figure 7. Profile Mode.

5.6. Main Menu

The Main Menu (Figure 8) provides access to a number of useful sub menus (Table 10). Access the Main Menu from the **Select a Mode** screen (Figure 4) by:







1. Simultaneously press  and .
2. Press  or  to navigate,  to select the highlighted option.
3. Press  to enter that mode.



Figure 8. Main Menu.

Table 10. Sub Menu Descriptions

Menu Item	Description
Mode Selection	Return to Select a Mode screen
Timer Mode	See Timer Mode Option (Section 5.4)
Profile Setup	Create, edit and delete profiles
Recorder Control	Start, stop and delete recordings on unit.
USB Menu	Access all read/write options to USB device
Configuration menu	Program all input and output settings
Automatic Tuning	Opens selection for Auto and Self Tune features
Product Information	Display information about unit
Service Information	Display name and address of service department

5.6.1. Profile Setup

Use Profile Setup to create, edit and delete profiles (Figure 9). Access the Profile Setup from the Main Menu screen. The Profiler option allows storage of up to 255 profile segments, shared between a maximum of 64 Profiles. Each profile controls the value of the setpoint over time; increasing, decreasing or holding its value as required. See Table 11 for Profile Setup options. Figure 10 shows the Protocol 3 Controller configuration options. Table 12 shows the full list of Profile Parameter options.



Figure 9. Profile Setup.

	<p>Find General Configuration Parameters in Section 5.7. Find Profile Setup in Section 5.6.1</p> <p>Note that other options are not visible until a profile is created.</p>
---	---

Table 11. Profile Setup Options.

Menu Item	Description
Edit a Profile Header	Change the name of any created profile
Edit a Profile Segment	Change the settings of a specific segment in a profile
Insert a Segment	Create a new segment in an existing profile
Delete a Segment	Delete a segment in an existing profile
Delete a Profile	Delete an existing profile
Delete all Profiles	Delete all profiles in the unit

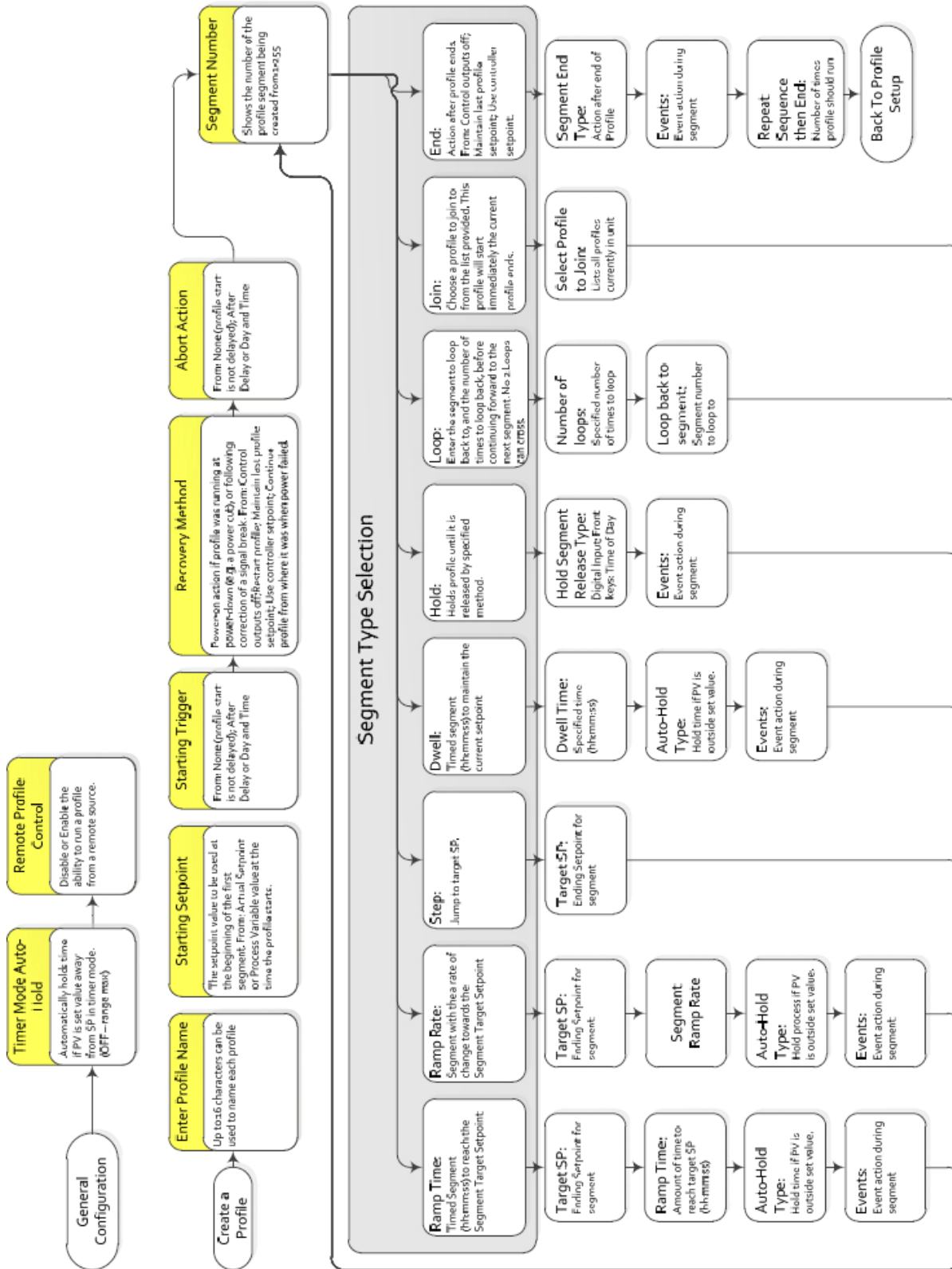









Figure 10. Profile Setup Menu.

Copyright © 2012 by Despatch Industries.

All rights reserved. No part of the contents of this manual may be reproduced, copied or transmitted in any form or by any means including graphic, electronic, or mechanical methods or photocopying, recording, or information storage and retrieval systems without the written permission of Despatch Industries, unless for purchaser's personal use.

5.6.1.1. Prepare for Profile Setup

Simultaneously press  and  to display the Main Menu:

1. Navigate to and highlight **Profile Setup**.
2. Press  to display **Profile Setup Enter Profiler Mode Unlock Code** screen.
3. Press  to enter Unlock Code 0010.
4. Press  to display the **Create a Profile** screen.
5. Press  to move right and  to move left. Press  or  navigate through numbers, uppercase letters and lower case letters.
6. After entering the profile name, press  as often as necessary to move to the next screen.



Before initiating the Profile Setup, use the programming worksheet (Section 8.2) to work out all parameters. Once the Profile Setup is begun, it must continue to the end or lose all entered values.

5.6.1.2. Sample Profile

Figure 11 shows a graphic representation of the sample profile, while Figure 12 shows the parameters entered to achieve that profile. Section 5.6.1.3 shows how to enter the profile.

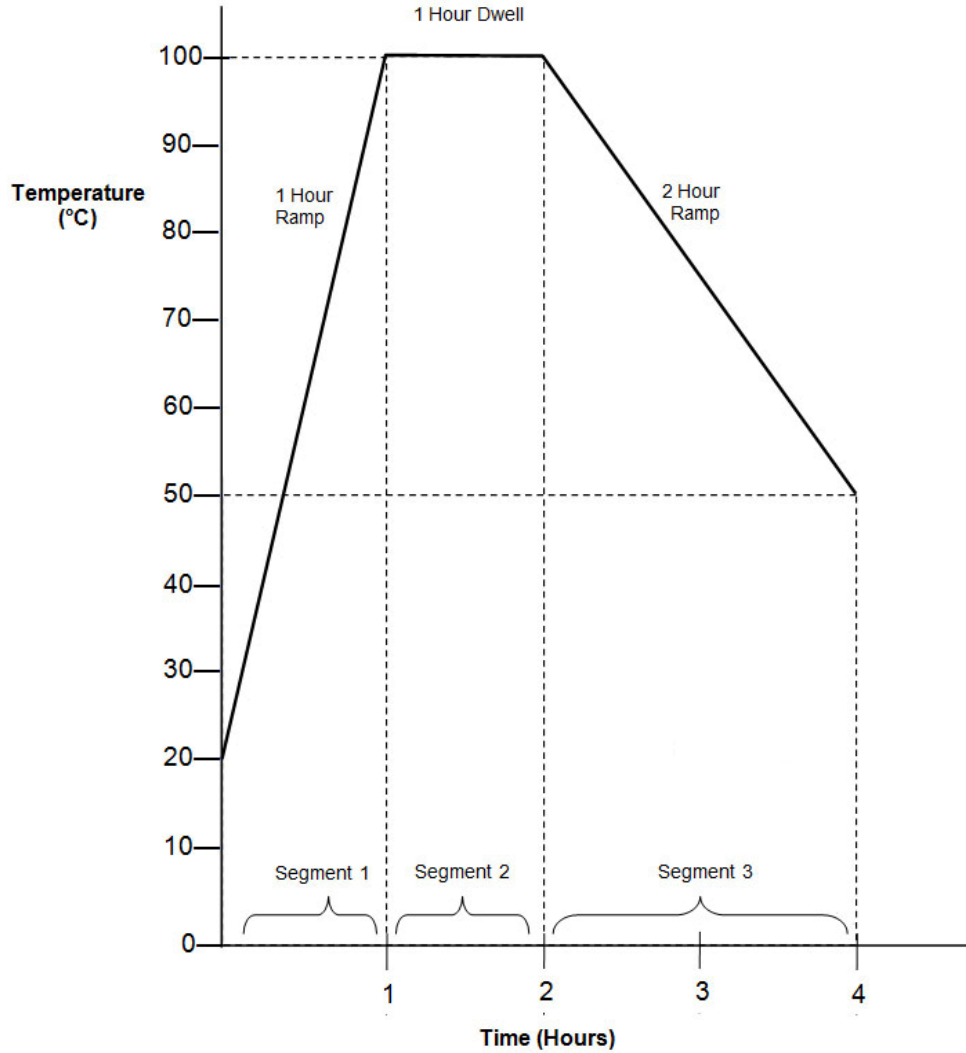

Figure 11. Sample Profile.



Profile Name: <i>1</i>									
Profile Number: <i>Profile 001</i>									
Segment	Segment Type	Target Setpoint	Time	Auto Hold Type	Events				
					1	2	3	4	5
<i>1</i>	<i>Ramp Time</i>	<i>100</i>	<i>01:00:00</i>	<i>None</i>					
<i>2</i>	<i>Dwell</i>		<i>01:00:00</i>	<i>None</i>					
<i>3</i>	<i>Ramp Time</i>	<i>50</i>	<i>02:00:00</i>	<i>None</i>					
<i>4</i>	<i>End</i>								

















Figure 12. Sample Profile Values.

5.6.1.3. Entering the Sample Profile Setup





To help show the process of setting up a profile, this section uses the sample profile as an example (from Figure 11 and Figure 12). Figure 10 shows the overall flowchart for working with Profile Setup. For entering sample values, we choose the default values.







Navigate to and Enter Profile Setup

From Select a Mode screen, simultaneously press  and  to display the Main Menu:







1. Navigate to and highlight **Profile Setup**.
2. Press  to display **Profile Setup Enter Profiler Mode Unlock Code** screen.
3. Press  to enter Factory Unlock Code 0010.
4. Press  to display the **Profile Setup** screen.
5. Press  to select **Create a Profile**.
6. Press  to enter mode.
7. Input unique Profile name: press  to move right and  to move left. Press  or  to navigate through numbers, uppercase letters and lower case letters.
8. After entering the profile name, press  as often as necessary to move to the next screen.
9. For **Profile Start Trigger**, when **None** is highlighted, press  to complete the entry.
10. For **Profile Recovery Method**, when **Control Off** is highlighted, press  to complete the entry.
11. For **Profile Abort Action**, when **Control Off** is highlighted, press  to complete the entry.
12. For **How Many Time to Cycle Program**, press  and  navigate to the desired number of cycles.
 - a. Press  to complete the entry.

Program Segment 1 according the Sample Profile (Figure 11 and Figure 12):











13. When **Segment Number 1** displays, press  .
14. Highlight **Ramp Time** and press  .
15. For **Target Setpoint**,
 - a. Press  or  navigate to 100°C (212°F).

- b. Press  to complete the entry.
- 16. For **Segment Ramp Time**,
 - c. Press  or  navigate to 1 hour (**01:00:00**).
 - d. Press  as needed to complete the entry.
- 17. For **Auto-Hold Type**, when **None** is highlighted, press  to complete the entry.
- 18. For **Event 1-5**, press  as needed to accept **Inactive**.



Program Segment 2 according the Sample Profile:

- 19. When **Segment Number 2** displays, press  .
- 20. Highlight **Dwell** and press  .
- 21. For **Dwell at 100.0°C (212 °F)**,
 - e. Press  or  navigate to 1 hour (**01:00:00**).
 - f. Press  as needed to complete the entry.
- 22. For **Auto-Hold Type**, when **None** is highlighted, press  to complete the entry.
- 23. For **Event 1-5**, press  as needed to accept **Inactive**.

Program Segment 3 according the Sample Profile:

- 24. When **Segment Number 3** displays, press  .
- 25. Highlight **Ramp Time** and press  .
- 26. For **Target Setpoint**,
 - g. Press  or  navigate to 20°C (68°F).
 - h. Press  to complete the entry.
- 27. For **Segment Ramp Time**,
 - i. Press  or  navigate to 2 hours (**02:00:00**).
 - j. Press  as needed to complete the entry.
- 28. For **Auto-Hold Type**, when **None** is highlighted, press  to complete the entry.
- 29. For **Event 1-5**, press  as needed to accept **Inactive**.

Program Segment 4 according the Sample Profile:

- 30. When **Segment Number 4** displays, press  .
- 31. Highlight **End** and press  .

	<p>Note: Last segment must be an End segment to exit Profile Entry Mode.</p>
---	---







- k. For **Segment End Type**, with **Control Off** highlighted, press  .
32. For **Profile Created**, press  .
33. Press  and  to display the **Main Menu**. Press  or  to select Mode Selection and press .

Table 12. Profile Parameter Options.



Profile Parameter	Options
Profile Limits	Number of profiles = 64 maximum. Total number of segments (all programs) = 255 maximum.
Loop Back Segments	1 to 9999 loops back to specified segment.
Profile Cycling	1 to 9999 or Infinite repeats per profile.
Sequence Repeats	1 to 9999 or Infinite repeats of joined profile sequences.
Segment Types	Ramp Up/Down over time, Ramp Rate Up/Down, Step, Dwell, Hold, Join A Profile, End or Repeat Sequence Then End.
Time-base	All times specified in hh:mm:ss (Hours, Minutes & Seconds).
Segment Time	Maximum segment time 99:59:59 hh:mm:ss. Use loop-back for longer segments (e.g. 24:00:00 x 100 loops = 100 days).
Ramp Rate	0.001 to 9999.9 display units per hour.
Hold Segment Release	Release With Key-press, At Time Of Day or via a Digital Input.
Start From Value	1st segment starts from current setpoint or current PV input value.
Delayed Start	After 0 to 99:59 (hh:mm) time delay, or at specified day(s) & time.
Profile End Action	Selectable from: Control Off , Maintain Last Profile SP , Control Off with Events . Use Controller Setpoint or Control Outputs Off.
Profile Abort Action	Selectable from: Keep Last Profile Setpoint, Use Controller Setpoint or Control Outputs Off.
Power/signal Loss Recovery Action	Selectable from: Continue Profile, Restart Profile, Keep Last Profile Setpoint, Use Controller Setpoint or Control Outputs Off.
Auto-Hold	Off or Hold if input >Band above and/or below SP for each segment.
Profile Control	Run, Manual Hold/Release, Abort or jump to next segment.
Profile Timing Accuracy	0.02% Basic Profile Timing Accuracy. <input type="checkbox"/> <0.5 second per Loop, End or Join segment.
Segment Events	Events turn on for the duration of the segment. For End Segments, the event state persists until another profile starts, the user exits from profiler mode, or the unit is powered down.

Copyright © 2012 by Despatch Industries.

All rights reserved. No part of the contents of this manual may be reproduced, copied or transmitted in any form or by any means including graphic, electronic, or mechanical methods or photocopying, recording, or information storage and retrieval systems without the written permission of Despatch Industries, unless for purchaser's personal use.

5.6.2. Recorder Control

Use Recorder Control to start, stop and clear recordings (Figure 13). Access the Recorder Control from the Main Menu.

1. Navigate to and highlight **Recorder Control**.
2. Press  to display **Recorder Control Enter Data Recorder Unlock Code** screen.
3. Press  as necessary to enter Factory

Unlock Code 0010.

4. Press  to display the **Start/Stop Data Recording** screen.
5. Press  or  to highlight and press  to **Stop Recording** or **Start Recording**.

The Recorder Status screen (Figure 14) displays after selecting an option.

Clear a recording while in Recorder Status screen by pressing  to advance to the **Clear Recordings** screen.



Figure 13. Recorder Control.

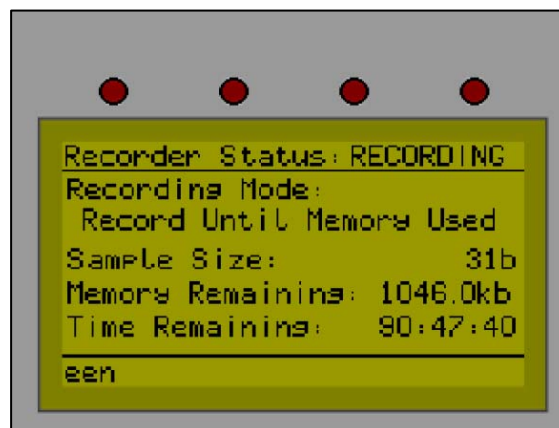



Figure 14. Recorder Status.



All recordings in the unit can be downloaded to a USB device using the USB port and the USB Menu.

5.6.3. USB Menu

Use **USB Menu** to perform read/write options for USB devices connected to the unit using the front USB port (Figure 15). Access the USB Menu from the **Main Menu**. See Table 13 for USB Menu options.

	<p>Note that a memory stick must be in place before the USB Menu will display.</p>
---	---

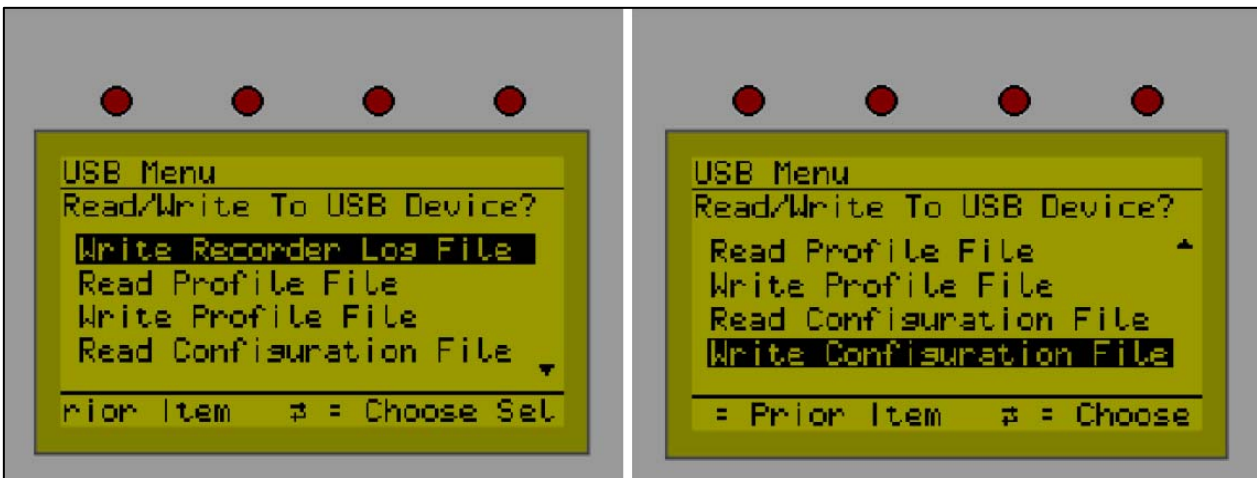

Figure 15. USB Menu.



1. Navigate to and highlight **USB Menu**.
2. Press  to display **Mode Unlock Code** screen.
3. Press  as necessary to enter Factory Unlock Code 0010.
4. Press  to display the **USB Menu** screen.

Table 13. USB Menu Options.

Menu Item	Description
Write Recorder Log File	Writes recorder Log data to USB
Read Profile File	Read profile from USB device to unit
Write Profile File	Write profile from unit to USB device
Read Configuration File	Read configuration file from USB device to unit
Write Configuration File	Write configuration file from unit to USB device

Copyright © 2012 by Despatch Industries.

All rights reserved. No part of the contents of this manual may be reproduced, copied or transmitted in any form or by any means including graphic, electronic, or mechanical methods or photocopying, recording, or information storage and retrieval systems without the written permission of Despatch Industries, unless for purchaser's personal use.



The Protocol 3 controller continues to control operations when initializing the USB memory stick. Allow time for initializing to complete before beginning new tasks.

5.6.3.1. Working with USB Memory Stick Folders and Files

Insert a memory stick into the port on the front panel (Figure 16). The Protocol 3 performs an initialization process that finds and/or creates folders on the memory stick (Figure 17):

- **DEVICE:** This folder must be located in the Root of the USB memory stick
- **CONFIG:** Configuration files (*.bct)
- **PROFILE:** Profile program files (*.pfl)
- **RECORDER:** Recorder log folders and files. The user is asked for a new recorder subfolder name before transferring recorder data to USB. The log files (*.csv) are placed in this folder.



Figure 16. USB Port on Front Panel.

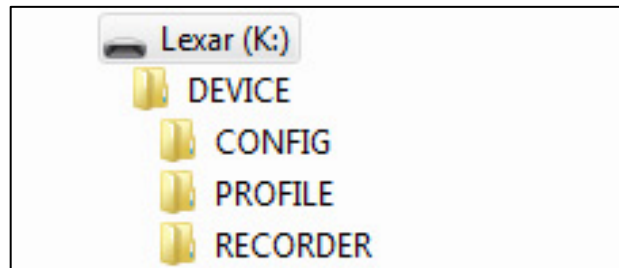





Figure 17. USB Files and Folders Requirements (as seen from Windows Explorer).

	<p><i>Files must be located in these folders to be used by the controller. When preparing to upload files from your PC, ensure that you save them to the correct folder on the memory stick.</i></p> <p><i>Note: to speed up the disk operation, keep the number of files stored in these folders to a minimum.</i></p>
	<p><i>If the file or folder named already exists, data will be overwritten.</i></p>
	<p><i>Do not remove the memory stick from the USB port while a data transfer operation is in progress. Data loss or corruption may result.</i></p>

Copyright © 2012 by Despatch Industries.

All rights reserved. No part of the contents of this manual may be reproduced, copied or transmitted in any form or by any means including graphic, electronic, or mechanical methods or photocopying, recording, or information storage and retrieval systems without the written permission of Despatch Industries, unless for purchaser's personal use.

5.6.3.2. File Naming Conventions

The Protocol 3 controller names the first recorder log file **000001-1.csv**. Each time the recording parameters are changed, a new file is created. For instance, changing the recording parameters two times would produce these file names:

- **000002-1.csv**
- **000003-1.csv**







Note that:

- Stopping or starting a recording does not create a new file.
- For any file exceeding 65,500 data lines, the Protocol 3 controller creates a new file with the last digit incremented by 1, for instance: **000001-2.csv**, then **000001-3.csv**.

	<p><i>During Data Transfer, normal operation carries on in the background but operator access to other screens is not possible.</i></p> <p><i>Transfer of full memory can take up to 12 minutes. Begin a transfer only when access (e.g. setpoint changes) will not be required.</i></p>
---	--

5.6.3.3. Create a New Name Before Writing to the USB Device

Before writing a file (**Write Recorder Log File**, **Write Profile File**, **Write Configuration File**), to the USB device, create a new name for the file or folder.









1. Insert the memory stick into the USB port.
2. For **Enter USB Mode Unlock Code**, press  to reach **0010**.
3. Press  to display the **Read/Write To USB Device?** choices:
 - a. **Write Recorder Log File**
 - b. **Read Profile File**
 - c. **Write Profile File**
 - d. **Read Configuration File**
 - e. **Write Configuration File**
4. For **Write Recorder Log File**, press  to display Enter a Folder Name.
5. Input unique file name: press  to move right and  to move left. Press  or  navigate through numbers, uppercase letters and lower case letters.
6. For **Confirm Write?**,
 - a. Press **No** to abort the process and return to the previous menu
 - b. Press **Yes** to continue to write the file or folder.

5.7. Configuration Menu

Configuration provides access to menus that allow for setting up 11 different options:

1. Input: Input settings and calibrate for process and High Limit Inputs
2. Control
3. Output
4. Alarm
5. Power Fail Recovery
6. Comms. (Communication)
7. Recorder
8. Clock
9. Display
10. Lock Code Configuration
11. Reset to Defaults

Navigate the configuration menus options using the flowchart (Figure 18) or Table 14. Figure 18 shows the Protocol 3 Controller configuration options. Access the Configuration from the Main Menu (Section 5.6):

1. Simultaneously press  and .
2. Navigate to **Configuration Menu** using  or .
3. Press  to **Enter Configuration Menu Mode Unlock Code.**
4. Press  to reach **0010**, the Mode Unlock Code.
5. Press  to display the configuration choices.
6. Navigate to the desired option using  and .

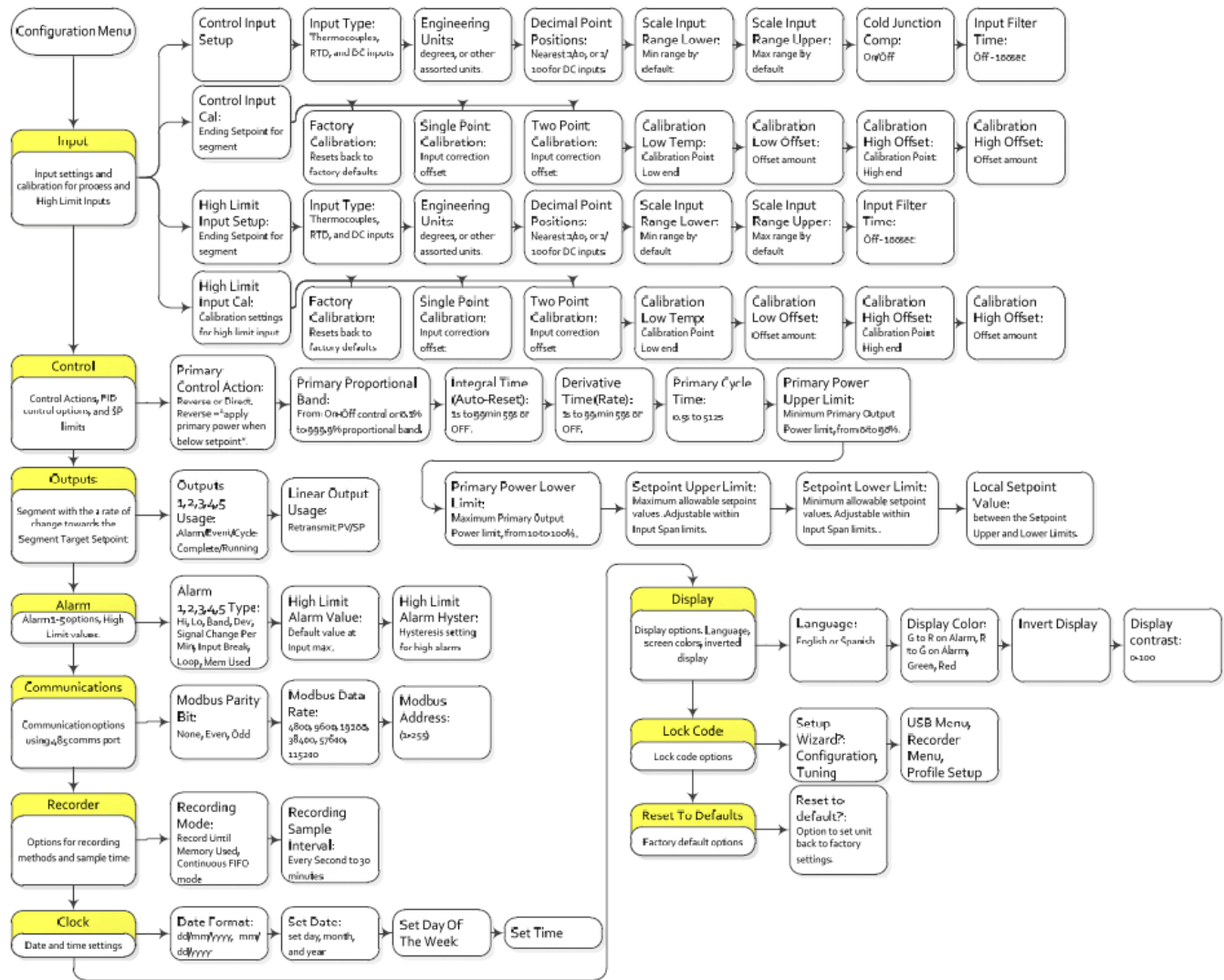

Figure 18. Configuration Menu (see also Table 14 for more information).

Table 14. Configuration Menu in Tabular Format.

Config-uration Menu	Description	Function	Available Settings
Input	Provide primary control and high limit settings	Control Input Setup	<ul style="list-style-type: none"> • Input Type: Thermocouples, PtRh, PT100, NI120, amperages, voltages • Engineering Units: °C, °F, °K, bar, %, %RH, pH, psi or none • Decimal Point Position: Nearest 1/10 or 1/100 for DC inputs • Scale Input Range (lower and upper limits): Min & Max range. Minimum range by default. • Input Filter Time: OFF-100 Sec • Cold Junction Compensation: Disable/Enable
		Control Input Calibration	<ul style="list-style-type: none"> • Factory Calibration: • Single Point Calibration: OFF, -400-+400° • Two Point Calibration: Low Temp. Low Offset, High Temp, High offset
		High Limit Input Setup	<ul style="list-style-type: none"> • Input Type: Thermocouples, PtRh, PT100, NI120, amperages, voltages • Engineering Units: °C, °F, °K, bar, %, %RH, pH, psi or none • Decimal Point Position: Nearest 1/10 or 1/100 for DC inputs • Scale Input Range (lower and upper limits): Min & Max range • Input Filter Time: OFF-100 Sec
		High Limit Input Calibration	<ul style="list-style-type: none"> • High Limit Process Variable: -250 • Factory Calibration: Resets back to factory defaults • Single Point Calibration: OFF, -400-+400° • Two Point Calibration: Low Temp, Low Offset, High Temp, High Offset
Control	Set control actions, PID control options and setpoint limits	Primary Action Control	<ul style="list-style-type: none"> • Reverse Action /Direct Action: Reverse applies primary power when below setpoint • Primary Proportional Band: From ON-Off control or set width of band from 0.1 to 999.9 • Integral Time (Auto-Reset): 1 sec to 99 min 59 sec or OFF • Derivative Time (Rate): 1 sec to 99 min 59 sec or OFF • Primary Cycle Time: 0.5 sec to 512 sec • Primary Power Upper Limit: Minimum primary power from 1 to 99% available power. Value must be higher than the lower limit. • Primary Power Lower Limit: Maximum primary power from 10 to 100% available power. Value must be lower than the upper limit. • Setpoint Upper Limit: Maximum allowed control setpoint • Setpoint Lower Limit: Minimum allowed control setpoint
Output	Set rate of	Output	<ul style="list-style-type: none"> • Output [1-5] Usage: Set Alarm, Event, Cycle

Copyright © 2012 by Despatch Industries.







All rights reserved. No part of the contents of this manual may be reproduced, copied or transmitted in any form or by any means including graphic, electronic, or mechanical methods or photocopying, recording, or information storage and retrieval systems without the written permission of Despatch Industries, unless for purchaser's personal use.

Config-uration Menu	Description	Function	Available Settings
	change toward Segment Target Setpoint	Configuration	Complete, Running, or combinations <ul style="list-style-type: none"> • Linear Output Usage: Set the desired type for any Linear Outputs fitted. From: 0-5, 0-10, 1-5, 2-10V & 0-20, 4-20mA or 0-10VDC adjustable Transmitter PSU. Parameters: Unused, Retransmit PV, Retransmit SP, Control Power
Alarm	Set alarm options and high limit values	Alarm Configuration	<ul style="list-style-type: none"> • Alarm [1-5] Usage: Set Alarm parameters: Unused, Process High, Process Low, PV-SP Deviation, Band, Signal Change Per Min, Input Signal Break, Control Loop, % Memory Used. • High Limit Alarm Value: 1-1000 • High Limit Alarm Hysteresis: Deadband on "safe" side of alarm, through which signal must pass before alarm deactivates.
Power Fail Recovery	Set Control Function on Power Failure	Restart Options	<ul style="list-style-type: none"> • Manual Mode Recovery: Control Off, Restart Manual Mode • Timer Recovery Method: Control Off, Restart Timer, Continue Timer
Communi-cations	Modbus Communicat-ion Settings	Set Up Communicati-ions	<ul style="list-style-type: none"> • Modbus Parity Bit: None, Even, Odd • Modbus Data Rate: 4800, 9600, 19200, 38400, 57600, 115200 • Modbus Address: 1-255
Recorder	Options for recording methods and sample time	Start and stop the Data Recorder	<ul style="list-style-type: none"> • Stop Recording: • Start Recording: • Recorder Status information: [see configuration menu] • Delete Recording:
Clock	Set date and time for internal clock	Clock Configuration	<ul style="list-style-type: none"> • Date format: dd/mm/yyyy or mm/dd/yyyy • Set Date • Set Day of Week (Choose day of week) • Set Time (hh/mm/ss format)
Display	Set options, language, screen color inverted display	Display Configuration	<ul style="list-style-type: none"> • Language: English or [Alternate language chosen at time of order] • Display Colour: Green to red on alarm, Red to green on alarm, Green, Red • Invert Display: Standard or negative display image • Display Contrast: 0-100
Lock Code	Set lock code options	Lock Configuration	<ul style="list-style-type: none"> • Configuration: Off, 1-9999 • Tuning: Off, 1-5000 • USB Menu: Off, 1-7000 • Recorder Menu: Off, 1-9999 • Profile Setup: Off, 1-9999
Reset to Defaults	Factor default options	Reset to Factory Configuration	<p>Reset All Parameters to Factor Defaults?</p> <p>All Setting Will be Lost!</p>

5.8. Automatic Tuning

	<i>Despatch does not recommend the use of Automatic Tuning. In most oven applications, standard configuration has been optimized.</i>
---	--

Access **Automatic Tuning** through the Main Menu (Section 5.6). The **Automatic Tuning** menu displays all the auto-tuning options provided in the unit. Table 15 provides additional information of each option.

1. Simultaneously press  and .
2. Navigate to **Automatic Tuning** using .
3. Press  to **Enter Automatic Tuning Mode Unlock Code.**
4. Press  to reach **0010**, the Mode Unlock Code.
5. Press  to step through and accept all automatic tune options.

To manually tune the controller, refer to **Control Configuration** in the **Configuration Menu** (Section 5.7).

Table 15. Automatic Tuning Options.

Menu Item	Description
Pre-Tune	A "single-shot" routine that disengages when complete.
Self-Tune	Continuous tuning routine that must be manually disengaged.
Auto Pre-Tune	If active, Pre-tune will attempt to run at every power up.

	<i>Automatic tuning will not engage if proportional band is set to ON/OFF control.</i> <i>Pre-tune and Auto Pre-Tune will not engage if the setpoint is ramping or the Process Variable is < 5% of span from setpoint.</i>
---	--

5.9. Product Information

Access **Product Information** through the Main Menu (Section 5.6). **Product Information** provides detailed information on the unit's software and hardware, such as calibration, firmware and production revision. Table 16 detailed description of the information is provided in the table below.

Press  to step through and accept all product information options.

Table 16. Product Information Details.

Menu Item	Description
Input Calibration Status	Calibration status of mVDC, VDC, mADC, RTD and Thermocouple CJC inputs. All should display as Calibrated
Optional Features	USB Port; Data Recorder (includes USB Port) or Profiler.
Firmware Information	Type and version of firmware.
Product Revision Level	Software and Hardware revision levels
Serial Number Information	Instrument serial number.
Date of Manufacture	Date of manufacture

5.10. Service Information

Access **Service Information** (Figure 19) through the Main Menu (Section 5.6). The **Service Information** menu displays contact information for service, sales or technical support.



Figure 19. Service Information Screen.

6. Maintenance

6.1. Replacement Parts

To order or return parts, contact the Despatch Global Service Network. The Service Products features our Response Center for customer service. When returning parts, a Despatch representative will provide you with an RMA (Return Material Authorization) number. Attach the RMA number to the returned part for identification. When ordering parts, expedite your process by providing model number, serial number and part number.

Global Headquarters	Contact	Service & Technical Support
Despatch Industries 8860 207th Street Lakeville, MN 55044 USA	International/Main: 1-952-469-5424 US toll free: 1-888-337-7282 Fax: 1-952-469-4513 info@despatch.com www.despatch.com	Service: 1-952-469-8230 US toll free: 1-800-473-7373 Service @despatch.com

7. Troubleshooting: Error Messages and Alarm

Table 17 lists the more common error messages, the possible problems and remedies.

Table 17. Error Messages and Next Steps.

Alarm Status	Possible Problem	Next Step
Hi-Limit LED ON	<ul style="list-style-type: none"> • Problem with thermocouple • Hi-limit setpoint has been exceeded. 	Once the problem has corrected, press Reset .
DEV HOLD LED flashing	Oven temperature has not entered (or dropped out of) the Auto Hold band and the soak timer has stopped	Program a slower ramp rate or if oven is not heating check heater circuit.
Top PV displays OPEN	Control thermocouple is disconnected or broken	Repair or replace the thermocouple.
HLPV displays OPEN	High Limit thermocouple is disconnected or broken	Repair or replace the thermocouple.

8. Appendices

8.1. Standard Products Warranty



Despatch
INDUSTRIES

Standard Products Product Warranty

Products Covered by this Warranty
This warranty (the "Warranty") applies to the following Despatch products: LEB, LBB, LAC, LCC, LCD, LLC, LLD, RAD, RFD, LND, TAD, TFD, FN, PTC, FCC, 900 Series.

Parts and Materials
Despatch warrants all parts and materials to be free from defects in material and workmanship for a period of:

- five (5) years from date of shipment for laboratory oven electric heaters;
- three (3) years from date of shipment for Protocol Plus, Protocol 3 and DES 2000 temperature controllers; and
- one (1) year from the date of shipment, or 2,000 hours of operation, whichever occurs first, for all other components of products covered by this Warranty.

During the applicable Warranty period, Despatch will repair or replace, at Despatch's option, parts and materials covered by this Warranty.

Labor
During the first 90 days of the Warranty period, Despatch will pay labor costs incurred to remove defective parts and materials, and to reinstall repaired or replacement parts or materials; provided, however, that Despatch's obligation to pay such labor costs shall be subject to the limitation that the removal and/or reinstallation service must be performed by a Despatch-authorized technician from Despatch's worldwide network of factory-trained professionals at a location within the contiguous United States.

Transportation Costs
All transportation costs to transport defective parts or materials to Despatch, and to transport repaired or replacement parts or materials to Customer, shall be the responsibility of the Customer.

Terms and Conditions
This Warranty shall be deemed valid and binding upon Despatch if and only if the Customer:

- installs, loads, operates, and maintains the covered product supplied hereunder in accordance with the instruction manual provided upon delivery and product labeling affixed to the subject equipment;
- if applicable, follows the Emergency Procedure set forth in this Warranty; and
- contacts Despatch's Helpline at 1-800-473-7373 for assistance in diagnosing and troubleshooting the problem immediately upon discovering any damage or malfunction.

Despatch's reasonable determination as to whether a repair, replacement, or service is covered by this Warranty shall be final and binding.

Exclusions
This Warranty DOES NOT cover:

- damage or malfunctions, or expenses incurred in the process of diagnosing and/or repairing damage or malfunctions, resulting from any of the following: operator error, misuse, abuse, inadequate preventive maintenance, normal wear and tear, service or modifications by other than Despatch authorized technicians, use of the covered product that is inconsistent with the operation manual or labeling, acts of nature (including, without limitation, floods, fire, earthquake, or acts of war or civil emergency), internal or external corrosion, or non-conforming utilities (including, without limitation, electrical, fuel supply, environmental and intake/exhaust installations);
- repair or replacement of parts or materials designed and intended to be expendable or consumable; refrigerants, filters, lamps;
- routine maintenance; or
- labor costs incurred for troubleshooting, diagnostics, or testing (except for testing required to verify that a covered defective part or material has been repaired).

Limitations of Liability
Despatch shall not, in any event, be liable for indirect, special, consequential, incidental, or punitive damages or penalties of any kind, including, without limitation loss of revenue, profits or business opportunities resulting from interruption of process or production. In no event shall Despatch be liable for damages in excess of the amounts paid by Customer to Despatch with respect to the applicable product(s). This Warranty does not cover, and Despatch shall not be liable for any losses, costs, damages or expenses resulting from delays in diagnosing or repairing the products, supplying or obtaining replacement parts or materials, strikes, labor stoppages or shortages, fires, accidents, government acts or regulations, or any other causes beyond the control of Despatch.

Non-Compliance By Customer
Despatch reserves the right to suspend and withhold service under this Warranty in the event of non-compliance by the Customer to any terms and conditions of this Warranty or the applicable purchase order or invoice. Further, Despatch shall not be liable for any loss of production, expenses, and inconveniences incurred due to such suspension.

Customer Furnished Equipment Warranty Limitation
This Warranty does not cover diagnosis or repairs of defects in or caused by, lack of performance of, or fitness for purpose of customer-supplied parts or equipment unless specifically noted in the Despatch written order acceptance confirmation.

Performance Commitment
Despatch provides no guarantee of process performance or fitness for purpose, unless specifically noted otherwise in Despatch written order acceptance confirmation. Despatch is providing equipment with design parameters specific only to its equipment.

Procedure Upon Discovery of Defects and Emergencies
In the event Customer becomes aware of any defect in the applicable products, Customer must immediately: (a) shut off fuel or energy supply (gas and electricity), (b) call for emergency assistance, if needed, and (c) notify Despatch Service.

THE REPRESENTATION AND WARRANTIES SET FORTH HEREIN ARE EXCLUSIVE AND IN LIEU OF, AND CUSTOMER HEREBY WAIVES AND DISCLAIMS RELIANCE UPON, ALL OTHER REPRESENTATIONS AND WARRANTIES OF EVERY KIND WHATSOEVER, WHETHER EXPRESS OR IMPLIED, OR ARISING BY OPERATION OF LAW OR IN EQUITY, OR BY COURSE OF PERFORMANCE OR DEALING OR USAGE OF TRADE, INCLUDING, WITHOUT LIMITATION, ANY IMPLIED WARRANTIES OF MERCHANTABILITY OR OF FITNESS FOR A PARTICULAR PURPOSE.

THIS WARRANTY IS PERSONAL TO THE CUSTOMER AND MAY NOT BE TRANSFERRED OR ASSIGNED. ALL LIMITATIONS HEREUNDER, HOWEVER, SHALL BE BINDING ON ALL SUCCESSORS AND ASSIGNS OF CUSTOMER.

Service
Phone 800-473-7373; International Phone 952-469-8230; Fax 952-469-8193
e-mail service@despatch.com; www.despatch.com

Please see reverse side for other service offerings BB7 (12/30/08)

Copyright © 2012 by Despatch Industries.

All rights reserved. No part of the contents of this manual may be reproduced, copied or transmitted in any form or by any means including graphic, electronic, or mechanical methods or photocopying, recording, or information storage and retrieval systems without the written permission of Despatch Industries, unless for purchaser's personal use.

8.2. Programming Worksheet

See Section 5.6.1 for help with completing Programming Worksheet (Table 18).

Table 18. Programming Worksheet.

Profile Name:									
Profile Number:									
Segment	Segment Type	Target Setpoint	Time	Auto Hold Type	Events				
					1	2	3	4	5

Copyright © 2012 by Despatch Industries.

All rights reserved. No part of the contents of this manual may be reproduced, copied or transmitted in any form or by any means including graphic, electronic, or mechanical methods or photocopying, recording, or information storage and retrieval systems without the written permission of Despatch Industries, unless for purchaser's personal use.

Copyright © 2012 by Despatch Industries.

All rights reserved. No part of the contents of this manual may be reproduced, copied or transmitted in any form or by any means including graphic, electronic, or mechanical methods or photocopying, recording, or information storage and retrieval systems without the written permission of Despatch Industries, unless for purchaser's personal use.

MINNEAPOLIS • SHANGHAI • BERLIN • SINGAPORE • HSINCHU • TOKYO • SEOUL

SERVICE AND TECHNICAL SUPPORT

Service parts: 1-800-473-7373

International service/main: 1-952-469-8230

Service fax: 1-952-469-8193

service@despatch.com

GLOBAL OFFICES

Germany: +49 30 629 073 410 / europe@despatch.com

China: +86-21-62365868 / shanghai@despatch.com

Taiwan: +886-3-6588484 / taiwan@despatch.com

Japan: +011-81-42-729-5355 / japan@despatch.com

USA HEADQUARTERS

Phone: 1-952-469-5424

US toll free: 1-888-337-7282

Fax: 1-952-469-4513

info@despatch.com

service@despatch.com

www.despatch.com

8860 207th Street West

Minneapolis, MN 55044 USA

Despatch
INDUSTRIES

© 2011 Despatch Industries. All rights reserved. Despatch is a registered trademark of Despatch Industries in the U.S. and other countries. No part of the contents of this manual may be reproduced, copied or transmitted in any form or by any means without the written permission of Despatch Industries, unless for purchaser's personal use.