

◆ LEB Natural Convection Benchtop Oven

Simple operation for general laboratory use

The Despatch LEB oven features natural convection that provides the most economical thermal processing. It is recommended for a variety of standard laboratory and production applications including drying, curing, annealing and materials testing.

Reliable, trouble-free performance

The LEB is designed and manufactured to provide years of dependable service. Despatch warrants the heater performance for a full five years – the best warranty in the industry. Every LEB oven is UL and C-UL listed open control panel and receives a thorough performance test before shipping.

Precise digital controls

Digital controls regulate temperatures within tight tolerances. A 3/4" (1.9cm) LED panel displays temperatures in large, bright, easy-to-read numbers. Temperatures can be reported in either Fahrenheit or Celsius.

Airflow Design

When forced convection airflow is not required, gravity or natural airflow offers high productivity at low cost. The heater generates quick heat-up as it covers the entire base of the chamber and allows the heated air to move through the perforated chamber floor.

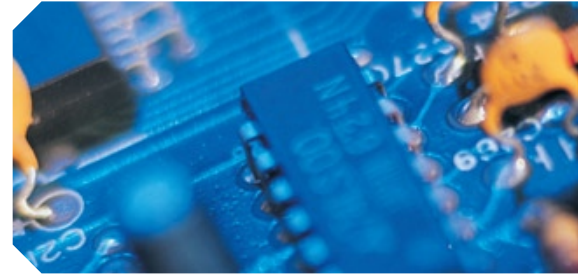

FEATURES AT A GLANCE

- ◆ Natural convection
- ◆ Temperatures up to 204° C (400° F)
- ◆ 304 Stainless steel interior
- ◆ Digital control with 3/4" (1.9cm) LED display
- ◆ Nickel plated shelves - by model rated from 50 to 100 lbs (23 to 45 kg)
- ◆ High-limit control
- ◆ Five year heater warranty

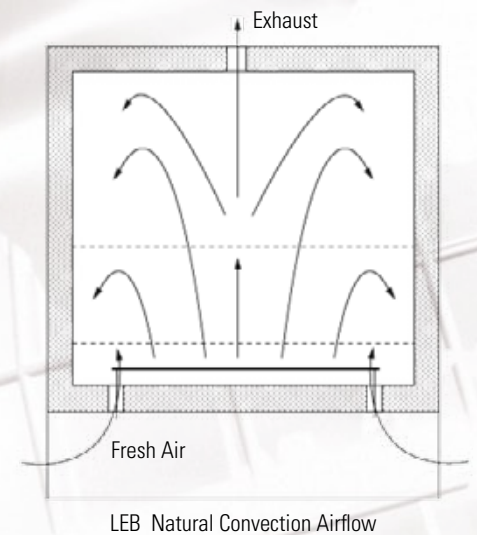

LEB		1-23		1-69		2-18	
PHYSICAL SPECIFICATIONS							
Chamber size (width x depth x height) <i>* Clear opening width is reduced by 3/4" (1.9 cm) due to 3/8" (.95 cm) shelf supports on each side.</i>		18* x 18 x 12 in 46* x 46 x 31 cm		30* x 18 x 22 in 77* x 46 x 56 cm		37* x 24 x 35 in 94* x 61 x 89 cm	
Capacity in cubic feet (liters)		2.3 (66)		6.9 (196)		18 (510)	
Overall size (width x depth x height)		24 x 24.5 x 26 in 61 x 63 x 67 cm		36 x 24.5 x 36.5 in 92 x 63 x 93 cm		43 x 30.5 x 51.5 in 110 x 78 x 131 cm	
Electrical single phase 50/60 HZ <i>* Operating at 208V will result in a 25% reduction in heater output. (Unless conversion kit is used)</i>	Volts*	120	240	120	240	240	
	Amps	10.4	5.2	20.4	10.2	15.2	
	Heater kW	1.2 kW		2.4 kW		3.6 kW	
Number of shelves provided		2		2		2	
Maximum number of shelves on 2 in. (5 cm) centers		5		10		16	
Number of doors		1		2		2	
Cord and plug		15 amp		None - Hardwire		None - Hardwire	
Approximate net weight		130 lbs (59 kg)		235 lbs (107 kg)		390 lbs (177 kg)	
Approximate shipping weight		195 lbs (89 kg)		310 lbs (141 kg)		475 lbs (216 kg)	
FUNCTIONAL SPECIFICATIONS							
Time to temperature with no load (25°C to 100°C)		20 minutes		18 minutes		20 minutes	
Time to temperature with no load (25°C to 200°C)		35 minutes		30 minutes		36 minutes	
Recovery time after door open for 1 minute (150°C)		4 minutes		4 minutes		4 minutes	
Recovery time after door open for 1 minute (204°C)		6 minutes		7 minutes		7 minutes	
Operating range		25°C to 204°C		25°C to 204°C		25°C to 204°C	
Control stability		+/- 0.5°C		+/- 0.5°C		+/- 0.5°C	
Maximum load capacity		75 lbs. (34 kg)		100 lbs. (45 kg)		150 lbs. (68 kg)	
Maximum shelf capacity (standard)		50 lbs. (23 kg)		50 lbs. (23 kg)		50 lbs. (23 kg)	
Maximum shelf capacity (reinforced)		n/a		100 lbs. (45 kg)		100 lbs. (45 kg)	

Notes: Time to temperature and recovery time are based on 240V/60hz operation. Actual results may vary slightly depending on unit configuration and operating conditions. Minimum operating temperature is based on 20°C ambient temperature measured at the fresh air inlet with the exhaust air damper fully open. Specifications are subject to change without notice.

Warning: Not for use with flammable or combustible materials. If your process has flammable solvents, contact Despatch.

OPTIONS

- ◆ Reinforced shelves rated to 100 lbs. (45 kg) (standard shelves rated to 50 lbs. (23 kg))
- ◆ Door with window and interior light
- ◆ Oven stacking hardware
- ◆ Process timer
- ◆ CE Conformance
- ◆ Chart recorder
- ◆ Access ports
- ◆ Oven stand

SERVICE AND TECHNICAL SUPPORT

service parts: 1-800-473-7373
international service/main: 1-952-469-8230
service fax: 1-952-469-8193
 service@despatch.com

GLOBAL HEADQUARTERS

phone: 1-888-DESPATCH (1-888-337-7282)
international/main: 1-952-469-5424
fax: 1-952-469-4513
 sales@despatch.com
 www.despatch.com

8860 207th Street West
 Minneapolis, MN 55044 USA

Despatch
INDUSTRIES